

**ALSAVO®**  
**Monobloc Heat Pump User Manual**  
(INVERBOOST Technology Air Source Heat Pump)



**ENGLISH**



Table of contents

1 – PLEASE READ BEFORE INSTALLATION ..... 2

    1.1 DOCUMENTS MANAGEMENT ..... 2

    1.2 RUNNING GENERAL FUNCTION ..... 2

    1.3 TRANSPORT INFORMATION ..... 4

    1.4 GAZ REGULATION AND MANIPULATION ..... 5

    1.5 SAFETY CONDITIONS ..... 6

2 – SPECIFICATIONS ..... 13

3 – DIMENSIONS ..... 15

4 – INSTALLATION, APPLICATION AND OPERATING ..... 16

    4.1 INSTALLATION ..... 16

    4.2 CONDENSAT EVACUATION ..... 16

    4.3 WIRING CONNECTION ..... 17

    4.4 HOW TO SELECT THE RIGHT PIPE SIZE ..... 19

    4.5 HOW TO SELECT THE RIGHT EXPANSION VESSEL & BUFFER TANK ..... 19

    4.6 ADVISED WATER FLUX ..... 19

    4.7 HOW TO SELECT THE RIGHT APPLICATION ..... 20

    4.8 APPLICATION MODES (12 MODES) ..... 21

    4.9 OPERATING LOGIC (PRIORITY MANAGEMENT) ..... 33

5 – CONTROLLEUR FUNCTION ..... 34

    5.1 Main function and icon introduction ..... 34

    5.2 Controller function ..... 35

    5.3 Setting of the heating (target temperature) ..... 41

    5.4 Setting of the DHW tank heating (electric mode) ..... 43

    5.5 Setting of the DHW tank heating (domestic water) ..... 43

    5.6 Setting of the sterilization mode DHW tank heating (domestic water) ..... 43

    5.7 Parameters data ..... 45

6 – TROUBLESHOOTING ..... 49

7 – APP CONNECTION ..... 53

    7.1 TUYA WIFI APP "Download" ..... 54

    7.2 Connection ..... 54

    7.3 Connection share ..... 55

8 – ELECTRONIC PCB ..... 58

9 – EXPLODED VIEW ..... 63

10 – MAINTENANCE ..... 75

# 1 – PLEASE READ BEFORE INSTALLATION

## 1.1 DOCUMENTS MANAGEMENT

### **Compliance with documents**

The installer must comply with the installation and operating instructions described in the manual.

### **Documentation management**

The installer provides the user with the manual for reference and safekeeping.

## 1.2 RUNNING GENERAL FUNCTION

### **Heat pump running function:**

It is a low carbon way to heat your house, the heat pump takes the energy on the air, the heat pump absorbs heat from the outside air into a liquid refrigerant at a low temperature. The compressor heats the liquid refrigerant to increase the temperature in the circuit and heat the water.

### **House heating:**

The hot water pass first in water tank and the circulator pump will push the water to go through convector, radiators or floor heating make the room heated.

On heating function the unit can run with ambient temperature from -20°C to 35°C.

### **House cooling:**

By reverse the cycle of running on the heat pump we can cool the water. To do that the installation must be equipped of convector and we can cool the house.

On cooling function, the unit can run with ambient temperature from 10°C to 43°C.

### **Domestic hot water:**

By using an enamel water tank, we can hot the sanitary water. The water sanitary stored is warm and supply the hot water for your hot taps, showers and baths.

### **Pool heating**

This heat pump is also an ideal choice for pool heating. Via heat ex-changer it can heat your private pool anytime, extend your swimming season.

### **Anti-freezing protection**

The heat pump as a protection anti-freezing function in running, but it was preconized to added glycol on the water circuit. This why is mandatory to disconnect electricity and shut down the heat pump during the winter season other way the function do not apply. The circulator starts if the ambient temperature is below 3°C and heat the water for anti-freezing protection.

In any way we must draining the water to avoid any risk of freezing when the heat pump is stop.

### **Operating range:**

To provide you comfort and pleasure, please set water temperature efficiently and economically.

Heat pump operation ambient temp. range: -15°C to 43°C

Heat pump operation water temp. range: 7°C to 55°C

## 1.3 TRANSPORT INFORMATION

### 1.3.1 Delivery of the unit

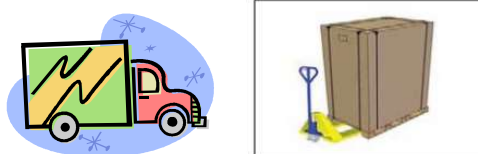

For transportation, the heat pumps are fixed on the pallet and covered with a cardboard box. To protect from any damage, the heat pump must be **transferred in its package**.

Even if transport is at the supplier's expense, any material may be damaged on its way to the customer, and it is the recipient's responsibility to ensure that the delivery conforms to specifications. The recipient must note any damage to the packaging on the carrier's delivery slip. **DO NOT FORGET TO SEND A REGISTERED LETTER TO THE CARRIER WITHIN 48 HOURS.**

### 1.3.2 Stock advice



The warehouse should be bright, spacious, open, well-ventilated, have ventilation equipment, and no fire source.

Heat pumps must be **stored and transferred in a vertical position** in their original packaging. If it is not the case, it cannot be operated until a minimum period of 24H has passed before the unit can have the electrical power turned on.

**FORBIDDEN**



### 1.3.3 Transfer to the final position

During the unpacking of the product and the transfer from the pallet to the final place of installation, it is necessary to maintain the heat pump in a vertical position.

**Smoking and the use of flames are prohibited near the R32 machine.**

## 1.4 GAZ REGULATION AND MANIPULATION



### Regulation (EU) No 517/2014 of 16/04/14 on fluorinated greenhouse gases and repealing Regulation (EC) No 842/2006.

#### Leakage control

Operators of equipment that contains fluorinated greenhouse gases in quantities of 5 tons of CO<sub>2</sub>, equivalent or more and not contained in foams shall ensure that the equipment is checked for leaks.

For equipment that contains fluorinated greenhouse gases in quantities of 5 tons of CO<sub>2</sub> equivalent or more, but of less than 50 tons of CO<sub>2</sub> equivalent: at least every 12 months.

#### Frequency of test

For equipment containing fluorinated greenhouse gases in quantities greater than or equal to 5 tons CO<sub>2</sub> equivalent but less than 50 tons CO<sub>2</sub> equivalent: at least every twelve months or, where a leak detection system is installed, at least every twenty-four months.

#### Training and certification

The operator of the relevant application shall ensure that the relevant personnel have obtained the necessary certification, which implies appropriate knowledge of the applicable regulations and standards as well as the necessary competence in emission prevention and recovery of fluorinated greenhouse gases and handling safety the relevant type and size of equipment.

#### Record keeping

Operators of equipment which is required to be checked for leaks, shall establish and maintain records for each piece of such equipment specifying the following information:

- a) The quantity and type of fluorinated greenhouse gases installed;
- b) The quantities of fluorinated greenhouse gases added during installation, maintenance or servicing or due to leakage;
- c) Whether the quantities of installed fluorinated greenhouse gases have been recycled or reclaimed, including the name and address of the recycling or reclamation facility and, where applicable, the certificate number;
- d) The quantity of fluorinated greenhouse gases recovered
- e) The identity of the undertaking which installed, serviced, maintained and where applicable repaired or decommissioned the equipment, including, where applicable, the number of its certificate;
- f) The dates and results of the checks carried out;
- g) If the equipment was decommissioned, the measures taken to recover and dispose of the fluorinated greenhouse gases.
- h) The operator shall keep the records for at least five years, undertakings carrying out the activities for operators shall keep copies of the records for at least five years.

## 1.5 SAFETY CONDITIONS

Please read this manual carefully before installing, modifying, or adjusting the heating system. This manual contains all the information you need to use and install the heat pump. The installer must read the manual and carefully follow the operating and maintenance instructions.

The installer is responsible for the installation of the product and must follow all the manufacturer's instructions and application rules. Failure to follow the instructions in this manual, or incorrect installation, will automatically **invalidate the warranty**.

Incorrect installation and use may result in serious injury or death, as well as damage to persons and property.

Zealux accepts no responsibility for damage to persons, property or errors caused by installations which do not follow the instructions in this manual. Any improper use will be considered dangerous.

**WARNING:** If you wish to remove the panels to gain access to the interior of the heat pump, be sure to switch off the power supply and avoid any risk of live contact.

**WARNING:** When you are not using the heat pump, to prevent the risk of freezing in sub-zero temperatures, you must :

- Leave the heat pump switched on, as it will operate at low temperatures and avoid any risk of freezing.
- In the event of a total power cut, drain the heat pump, otherwise the plate heat exchanger will be damaged by frost.
- The hot water circuit must be mixed with a maximum of 50% propylene or ethylene glycol. The mixture must provide frost protection for the heat pump's hydraulic circuit. It is forbidden to discharge glycol water into drains or the environment.

**Failure to comply with these instructions will result in total loss of warranty.**

**WARNING:** Install the controller in a dry location, preferably indoors and always under cover, to avoid damage caused by humidity.

Installation must be carried out by qualified personnel in strict compliance with Zealux recommendations.

**The precautions listed here are divided into the following categories.**

Meaning of DANGER, WARNING AND CAUTION icons.

**DANGER** 

Indicates an imminently hazardous situation which, if not avoided, will result in death or serious injury.

**WARNING** 

Indicates a potentially hazardous situation which, if not avoided, may result in minor or moderate injury.

**ATTENTION** 

Indicates a potentially hazardous situation that may result in minor or moderate injury.

We recommend that you read and follow the recommendations below before operating the unit.

---

## 1.5.1 DANGER

---



- Risk of electric shock due to incorrect connection to the mains supply.
  - Non-compliance with the rules of the art when making electrical connections can lead to the risk of electric shock and material damage.
- Be sure to install protective circuit breakers in accordance with local laws and regulations.
  - Failure to install a protective device may result in a risk of electric shock and fire.
- Before working on the heat pump, switch off the power supply via the circuit breaker.
- When the service panels are removed, the user must take all necessary precautions to avoid any incident.
- Never leave the unit unattended during installation or maintenance when the service panel is removed.
- Do not touch the water pipes during and immediately after operation, as they may be hot. To avoid injury, allow the pipes to cool to normal temperature, or wear protective gloves.
- Do not touch any switch with wet fingers. Touching a switch with wet fingers can cause an electric shock.
- Before touching electrical parts, switch off the power supply to the unit.
- To avoid burns, do not touch the machine's inlet and outlet pipes while the machine is running.
- To avoid cuts, do not touch the machine's radiator fins directly with your hands.
- Ask your dealer or a qualified person to follow the instructions in this manual for installation work. Do not install the unit yourself. Incorrect installation may lead to water leakage, electric shock or fire, resulting in injury, death or property damage.
- Be sure to use the accessories and parts supplied by the manufacturer during installation. Incorrect use of other parts can lead to water leaks, electric shock and product malfunction.
- Ensure that all electrical work is connected by a qualified person using a separate mains supply in accordance with local laws and regulations and this manual. Insufficient circuit capacity or incorrect electrical construction can lead to fire and malfunction.
- Be sure to install earth leakage circuit breakers in accordance with local laws and regulations. Failure to install an RCD may result in electrocution in the event of malfunction or water leakage in the system

---

## 1.5.2 **WARNING**

---



- Work on the heat pump (such as installation, repair, connection and initial commissioning) may only be carried out by authorized personnel who have successfully completed a qualified technical or vocational training course and attended a refresher course. This applies to heating engineers and air-conditioning technicians who, by virtue of their technical training and knowledge of heat pumps, are experienced in the installation and maintenance of heating, air-conditioning and cooling equipment, as well as heat pumps. However, due to the different designs of different brands of heat pumps, it is essential to read this manual carefully and to use the unit in accordance with the instructions.
- **The heat pump must be kept permanently underpowered, especially during the winter season, to protect it from freezing.**

### **Installation precautions:**

- Safely dispose of packaging materials such as staples and other metal or wooden parts that could cause injury.
- Mount the unit on a base or stand capable of supporting its weight and elevate it to allow condensate to drain easily.
- An unstable base or support may cause the unit to fall, resulting in injury.
- During installation, it is necessary to take into account the impact of strong winds and hurricanes on the installation, to adjust the position and to reinforce its stability.

### **Electrical wiring safety :**

- Electrical installation must be carried out by professionals in accordance with current electrotechnical guidelines and the regulations of the relevant energy supply company.
- Prior to any intervention, disconnect the power supply (turn off the main switch, break the circuit breaker) and secure against unintentional restart.
- Ensure that all wiring is correctly dimensioned. Ensure that terminal connections and cables are protected from water and moisture. Incomplete connections or fastenings can cause fires.

- Connect the device to earth, in compliance with local laws and regulations. Do not connect the earth cable to the gas or water pipe, or to the lightning protection cable. This could cause a fire. Incomplete grounding may result in electric shock.
- When wiring the power supply, ensure that the terminal block is securely fastened. If the terminal block is not tightened sufficiently, the terminals may overheat and cause a fire.

### **HFC gaseous refrigerant:**

- After completing the installation work, check that there are no refrigerant leaks.
- There is refrigerant in the refrigeration circuit, which can be very cold or very hot. Do not touch the refrigeration circuit during and immediately after operation. Burns or frostbite may occur if the copper pipes in the refrigeration circuit are touched. To avoid injury, allow the pipes to return to normal temperature, or wear protective gloves if you must touch them.
- Never touch leaking refrigerant directly, as this can cause serious injury.
- When working on the refrigerant circuit, make sure the workplace is well ventilated. Never work on the refrigerant circuit in closed rooms or confined spaces.
- Do not allow HFC refrigerant gas to encounter flames, embers or hot objects, otherwise there is a risk of flashover.
- Never allow HFC refrigerant gas to escape into the atmosphere (this is prohibited and is harmful to the environment).
- When removing service hoses from fill fittings, never hold the fittings in the direction of your body. Residual HFC refrigerant gas could escape.

### **Water connection:**

- **We recommend dosing the water circuit with "glycol" to protect the heat pump exchanger from any risk of freezing during the cold season. Despite the frost protection, leaving the machine switched on may result in a power failure, which may result in the water circuit not being protected.**
- Always wear safety glasses and protective gloves.
- Contact with internal parts may cause burns. To avoid injury, allow internal parts to cool down to normal temperature, or wear protective gloves if you must touch them. And to

avoid electric shock, please disconnect the unit from the power supply before working on it.

- Seals must not be damaged or removed during assembly.
- The domestic water connection must comply with local drinking water standards.

**More general information :**

- Do not touch internal parts (pump, etc.) during and immediately after operation.
- This device must not be used by minors. Before using it, please undergo appropriate training and read this manual to understand the hazards involved.
- Children must be supervised to ensure that they do not play with the equipment, and that they stay away from the site during installation.
- Equipment covers and service panels must be replaced as soon as work is completed.
- Original spare parts are strongly recommended, as components and spare parts must at least meet the technical requirements defined by the manufacturer.

---

### **1.5.3 ATTENTION**

---



Do not install this device in the following locations:

- a) Where oil mist or vapor is present, plastic components may age and loosen or leak.
  - b) The use of a corrosive gas (such as sulfuric acid) can corrode copper tubes or soldered parts and lead to refrigerant gas leaks.
  - c) In an area where electromagnetic waves are emitted, they can interfere with control systems and electronic boards and cause equipment failure.
  - d) Where there may be leaks of flammable gases or combustible dust suspended in the air, or where volatile flammable products such as paint thinner, or gasoline are handled. These volatile products can cause fires.
  - e) Places where air salinity is very high, such as near the ocean, cause corrosion and premature ageing.
  - f) Power grids with high voltage fluctuations.
  - g) In a vehicle or on a boat.
  - h) In the presence of acidic or basic vapors.
- End of product life: Do not dispose of this product at the municipal landfill like any other common product. It is mandatory to collect this product separately for special treatment. Do not dispose of electrical appliances at the municipal landfill, use a designated collection area, contact your local authority for information on available collection systems. If appliances are disposed of in landfill sites, hazardous substances may seep into groundwater and enter the food chain, harming human health.

## 2 – SPECIFICATIONS

Alsavo model			ALSAVO HEAT 07i	ALSAVO HEAT 10i	ALSAVO HEAT 12i
Suggested buffer tank			60L	60L	60L/80L
Heating Swimming Pool at Air 15°C, Water 30/35°C	Heating capacity	kW	8.10	13.90	16.10
	Power input	kW	1.62	2.78	3.22
	COP		5.00	5.00	5.00
Heating at Air -7°C, Water 30/35°C	Heating capacity	kW	3.96	6.47	7.67
	Power input	kW	1.25	2.10	2.37
	COP		3.17	3.09	3.23
Heating at Air -7°C, Water 50/55°C	Heating capacity	kW	3.67	6.79	7.57
	Power input	kW	1.71	3.06	3.38
	COP		2.14	2.22	2.24
Heating at Air 7°C, Water 30/35°C	Heating capacity	kW	1.80	2.79	3.33
	Power input	kW	0.31	0.42	0.57
	COP		5.87	6.72	5.85
Heating at Air 7°C, Water 50/55°C	Heating capacity	kW	1.63	2.88	3.31
	Power input	kW	0.39	0.61	0.78
	COP		4.15	4.69	4.23
<b>General Data</b>					
Compressor type			Inverter compressor		
Power supply		V	220-240V/50Hz/1PH		
Rated heating capacity		kW	7	10	12
Max Power Input		kW	3.34	3.89	5.43
Rated Current		A	14.0	16.0	23.0
Minimum Fuse Current		A	17.0	20.0	28.0
Suggested water flux		m <sup>3</sup> /h	1.2	1.7	2.1
Water connection			G1"	G1"	G1"
Heat exchanger			Plate exchanger		
Net weight		kg	70	76	99
Gross weight		kg	86	92	117
Net dimension		mm	1076*456*860	1076*456*860	1052*453*1260
Packing dimension		mm	1140*536*1005	1140*536*1005	1110*533*1405

Alsavo model			ALSAVO HEAT 16i	ALSAVO HEAT 12iT	ALSAVO HEAT 16iT
Suggested buffer tank			80L/100L	60L/80L	80L/100L
Heating Swimming Pool at Air 15°C, Water 30/35°C	Heating capacity	kW	23.80	16.00	24.20
	Power input	kW	4.76	3.20	4.84
	COP		5.00	5.00	5.00
Heating at Air -7°C, Water 30/35°C	Heating capacity	kW	10.66	7.48	10.66
	Power input	kW	3.46	2.36	3.42
	COP		3.08	3.17	3.12
Heating at Air -7°C, Water 50/55°C	Heating capacity	kW	11.03	7.42	10.84
	Power input	kW	5.66	3.67	5.40
	COP		1.95	2.02	2.01
Heating at Air 7°C, Water 30/35°C	Heating capacity	kW	4.34	3.04	4.25
	Power input	kW	0.78	0.49	0.72
	COP		5.56	6.17	5.91
Heating at Air 7°C, Water 50/55°C	Heating capacity	kW	4.49	3.31	4.25
	Power input	kW	1.11	0.76	1.02
	COP		4.06	4.34	4.17
<b>General Data</b>					
Compressor type			Inverter compressor		
Power supply		V	220- 240V/50Hz/1PH	380-415V/50Hz/3PH	
Rated heating capacity		kW	16	12	16
Max Power Input		kW	6.51	5.43	6.37
Rated Current		A	26.0	12.0	12.0
Minimum Fuse Current		A	32.0	15.0	15.0
Suggested water flux		m <sup>3</sup> /h	2.8	2.1	2.8
Water connection			G1"	G1"	G1"
Heat exchanger			Plate exchanger		
Net weight		kg	107	99	107
Gross weight		kg	125	117	125
Net dimension		mm	1052*453*1260	1052*453*1260	1052*453*1260
Packing dimension		mm	1110*533*1405	1110*533*1405	1110*533*1405

\*The above data is only a reference. please refer to the nameplate on the unit.

### 3 – DIMENSIONS

**Models:** ALSAVO HEAT 07i/ ALSAVO HEAT 10i

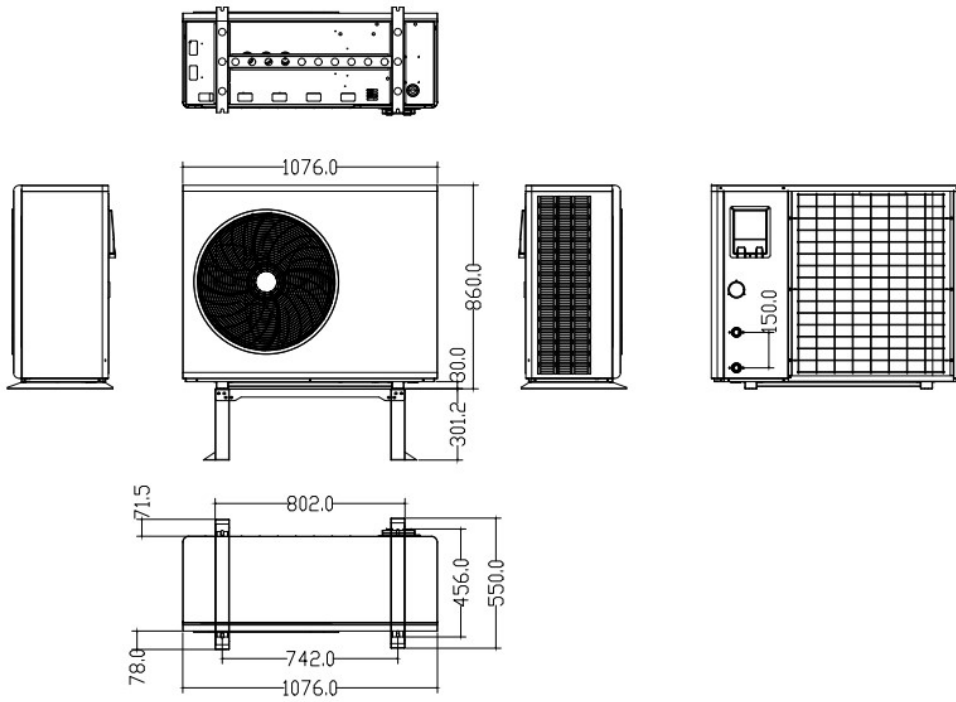

**Models:** ALSAVO HEAT 12i, ALSAVO HEAT 12iT, ALSAVO HEAT 16i, ALSAVO HEAT 16iT

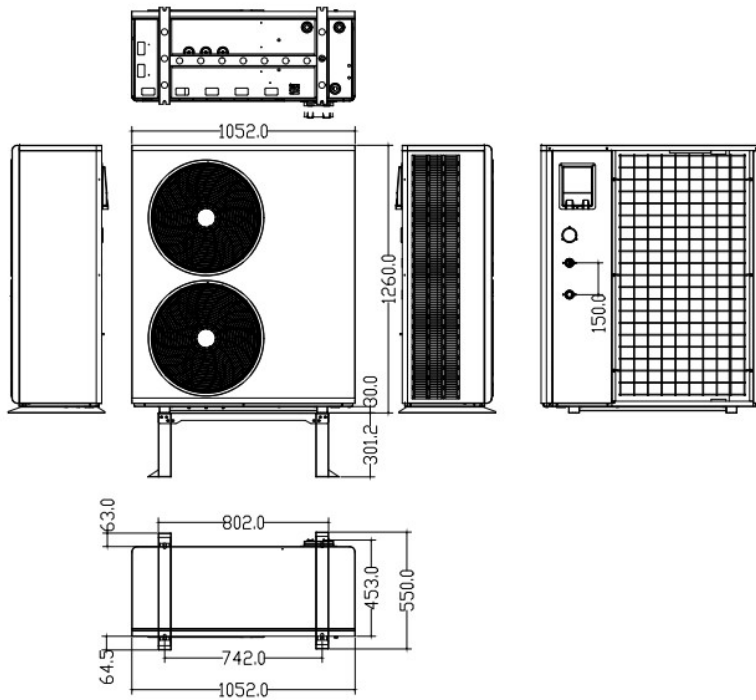

Unit: mm

## 4 – INSTALLATION, APPLICATION AND OPERATING

### 4.1 INSTALLATION

The illustration below shows the minimum distance required on each side of the heat pump. Failure to observe these distances will result in malfunction and reduced performance.

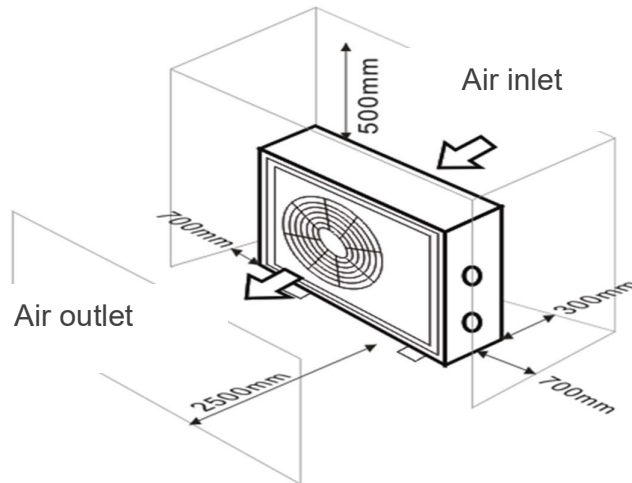

### 4.2 CONDENSAT EVACUATION

Significant condensation (several liters) is a sign or proper operation of the heat pump. When the phenomena happen, there is a significant discharge of water and it is necessary to provide at the installation a drainage so that the water must be evacuate quickly.

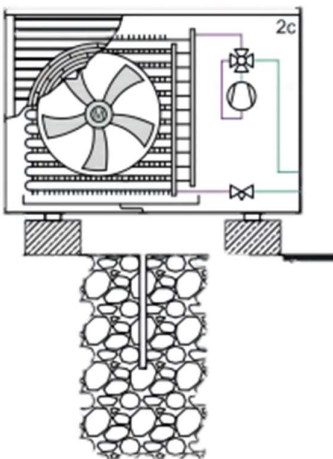

A condensate pan for an outdoor air-conditioning unit is a receptacle that collects the condensate (the water that forms when air is cooled) produced by an air-conditioning unit. It is designed to evacuate water safely and efficiently, preventing water damage and mold problems.

It must be expected that condensates will not go on the access roads in particular in winter (ice formation) and risk of accident. For this there are condensate recovery tanks to be provided from 1<sup>st</sup> installation of the heat pump.

#### 4.3 WIRING CONNECTION

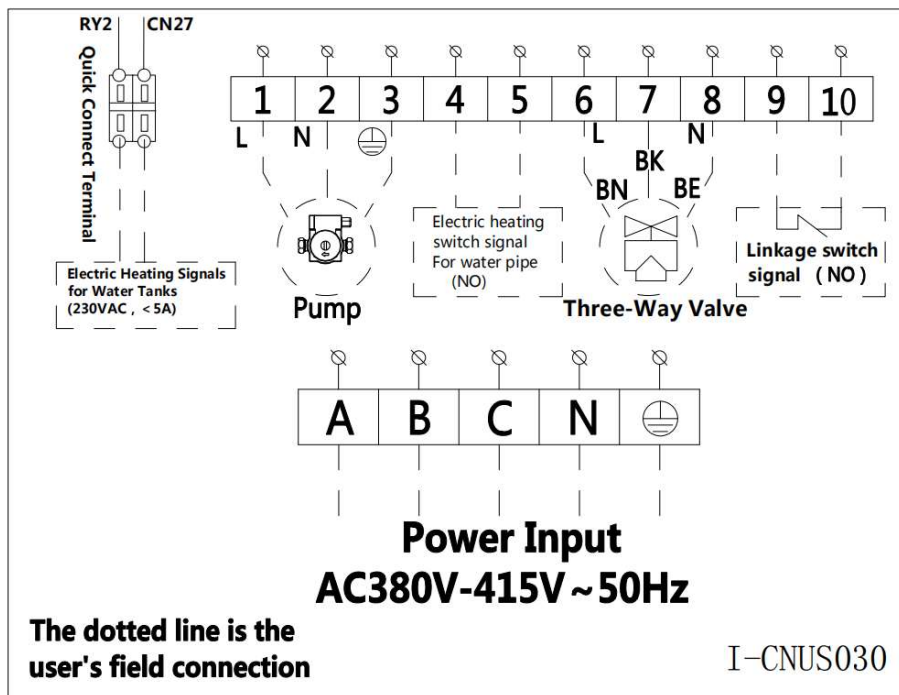
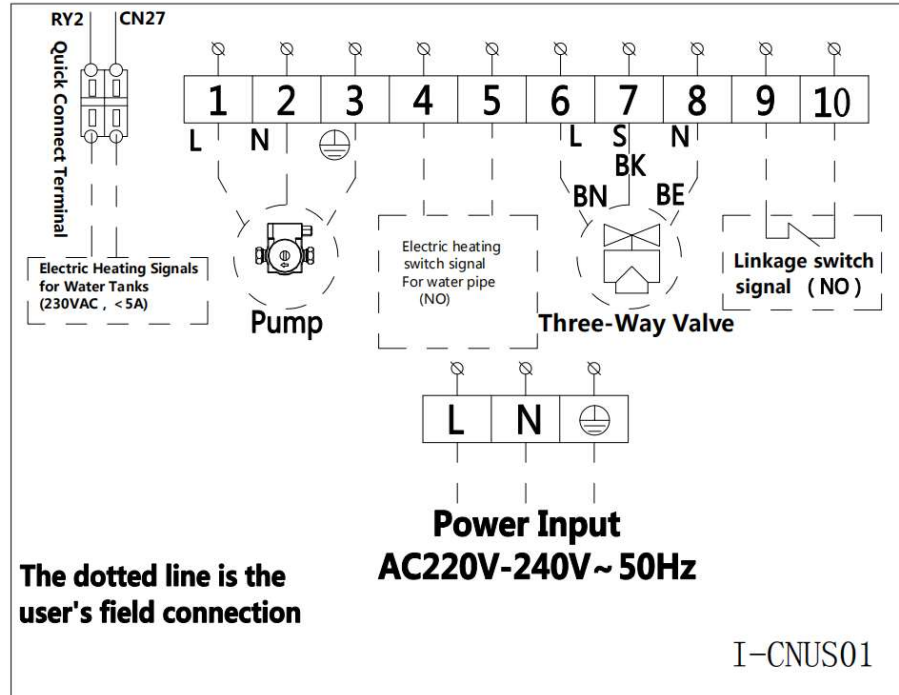

1. For terminals 1 to 3, they are connected to circulator pump. **or models integrated with circulator pump, they are already connected in default.** If you have external circulator pump, you can also connect to these terminals.
2. For the terminal 4 & 5, they are for the auxiliary heater.
3. For terminals 6 to 8, they are for the three-way valve.
4. For terminal 9 to 10, they work as a switch to control the heat pump. They are connected in default. If you need to control the heat pump by additional switch, you can connect your device to these terminals.

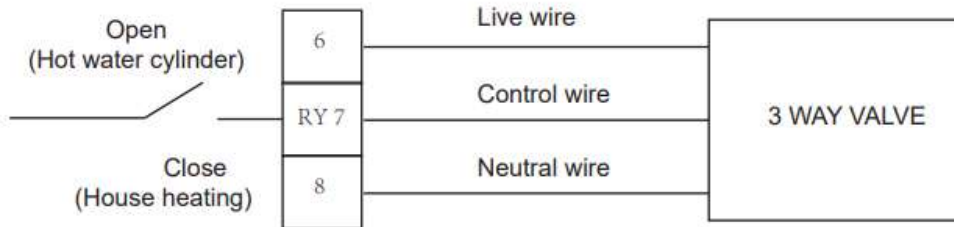

#### 4.4 HOW TO SELECT THE RIGHT PIPE SIZE

Please note that these sizes are for guidance only and may differ depending on pipe run, pressure losses within the system and amount of bends.

Table of recommendations for pipework:

<b>Model</b>	<b>Metal</b>	<b>PPR</b>	<b>Copper</b>
ALSAVO HEAT 07i	DN32	DE40	28mm
ALSAVO HEAT 10i	DN32	DE40	28mm
ALSAVO HEAT 12i	DN32	DE40	28mm
ALSAVO HEAT 12iT	DN32	DE40	28mm
ALSAVO HEAT 16i	DN32	DE40	28mm
ALSAVO HEAT 16iT	DN32	DE40	28mm



#### 4.5 HOW TO SELECT THE RIGHT EXPANSION VESSEL & BUFFER TANK

<b>Model</b>	<b>Expansion vessel</b>	<b>Buffer tank</b>
ALSAVO HEAT 07i	5L	60L
ALSAVO HEAT 10i	5L	60L
ALSAVO HEAT 12i	5L	60L/80L
ALSAVO HEAT 12iT	5L	60L/80L
ALSAVO HEAT 16i	5L	80L/100L
ALSAVO HEAT 16iT	5L	80L/100L













#### 4.6 ADVISED WATER FLUX

<b>Model</b>	ALSAVO HEAT 07i	ALSAVO HEAT 10i	ALSAVO HEAT 12i	ALSAVO HEAT 16i	ALSAVO HEAT 12iT	ALSAVO HEAT 16iT
Advise water flux (m <sup>3</sup> /H)	1.2	1.7	2.1	2.8	2.1	2.8







## 4.7 HOW TO SELECT THE RIGHT APPLICATION

Press and hold the clock button  and the up button  together for 3 seconds to enter the parameter setting interface (more setting details see section 2.2 of the CONTROLLER chapter), select the corresponding P20 parameter according to the actual terminal device that needs to be connected as below:

Default setting P20=2.

- P20=1, Domestic water tank mode 
- P20=2, Space heating mode 
- P20=3, Domestic water tank heating / space heating mode  / 
- P20=4, Space cooling mode 
- P20=5, Domestic water tank heating / space cooling mode  / 
- P20=6, Space heating / cooling mode  / 
- P20=7, Domestic water tank heating / space heating / cooling mode  /  / 

### Steps:

- 1) Press clock  and up arrow  simultaneously for 3 seconds to access P parameters.
- 2) Select P20 to set parameters as required (see list above) and use the  up arrow to scroll through the P modes. (1-34)
- 3) To modify parameter P20, press the clock .
- 4) Select the desired setting from 1 to 7 and press the clock  again to confirm.
- 5) To return to the main interface, press the on/off button  once.

## 4.8 APPLICATION MODES (12 MODES)

### Application 1

P20=2, Space heating mode ☀️

P20=4, Space cooling mode ❄️

P20=6, Space heating / cooling mode ☀️ / ❄️

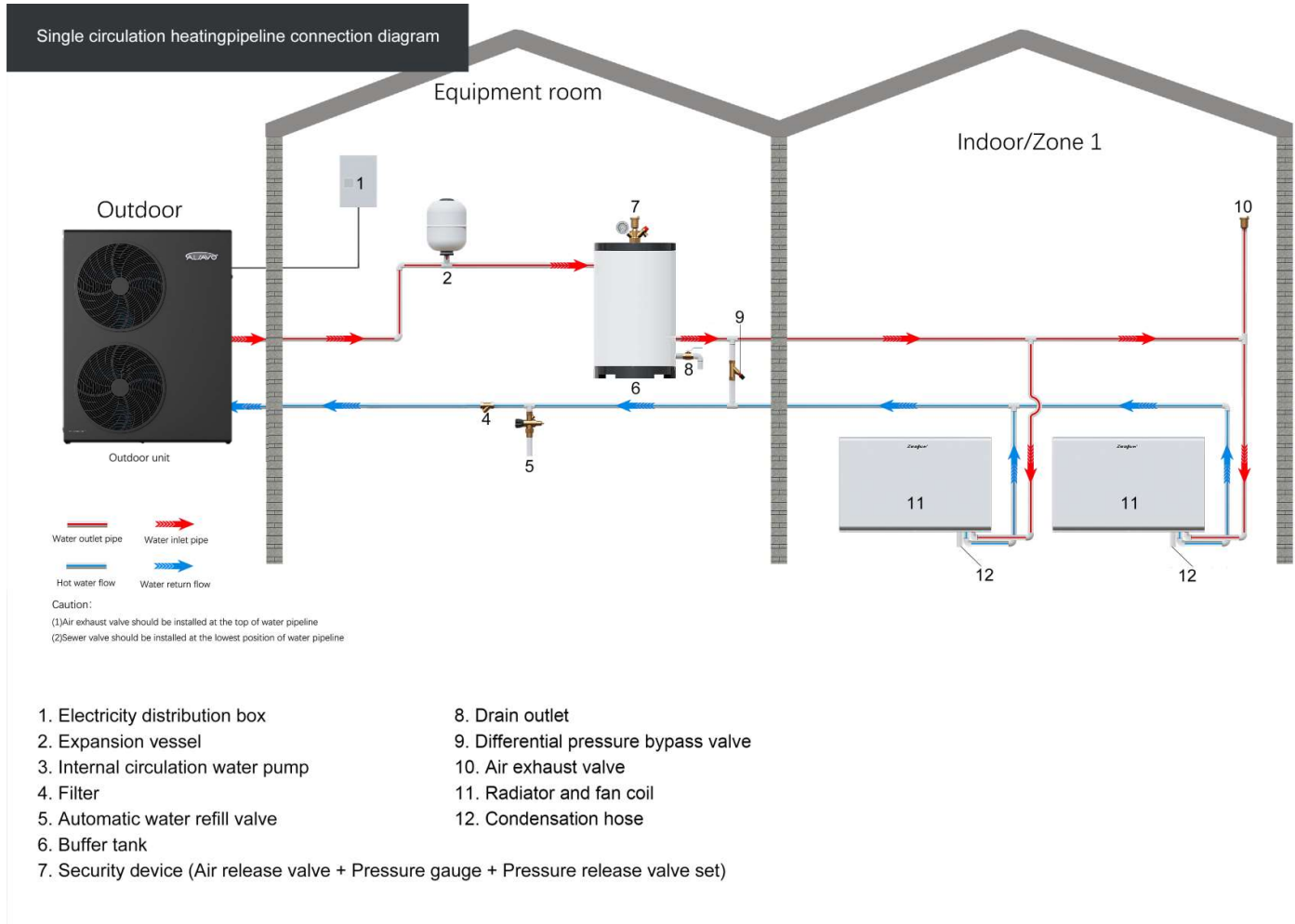

## Application 2

P20=7, Domestic water tank heating / space heating / cooling mode 

Single circulation heating +hot water pipeline connection diagram

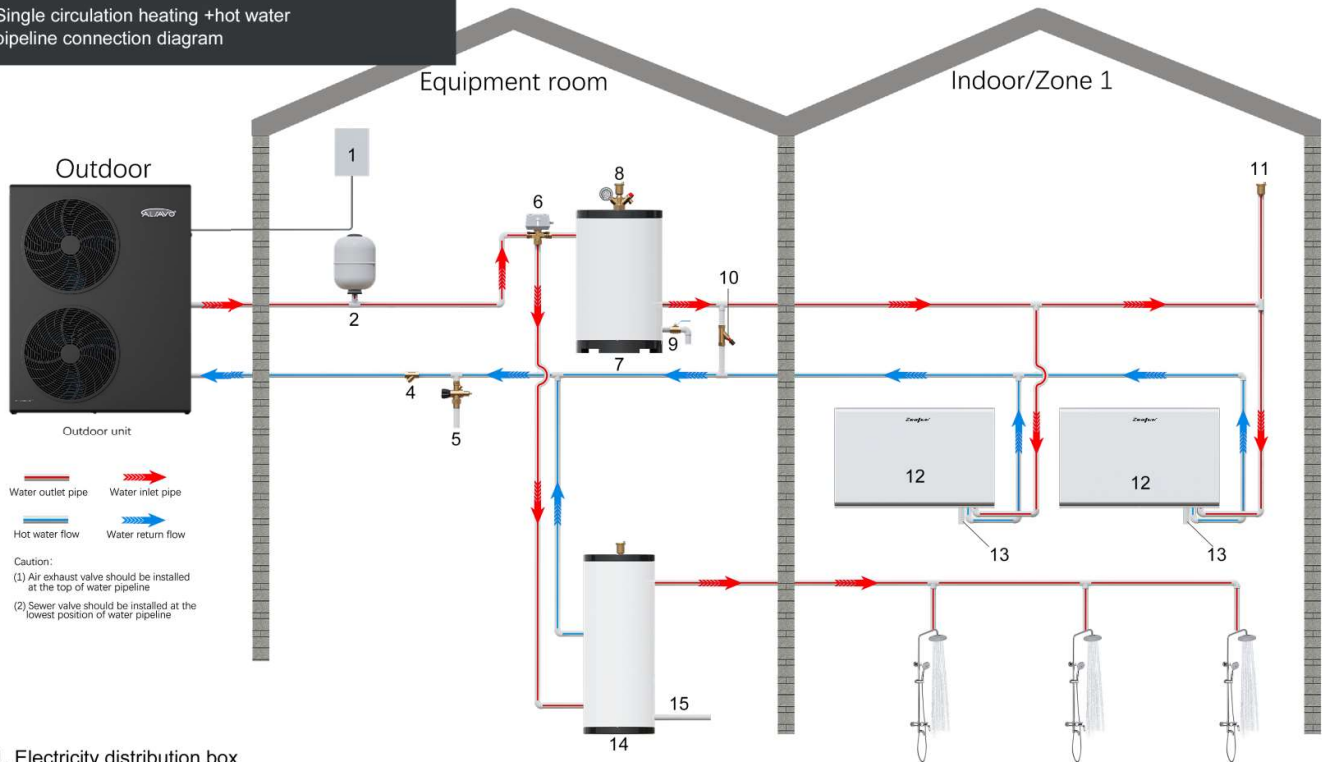

1. Electricity distribution box
2. Expansion vessel
3. Internal circulation water pump
4. Filter
5. Automatic water refill valve
6. 3 way electromagnetic valve
7. Buffer tank
8. Security device (Air release valve + Pressure gauge + Pressure release valve set)

9. Drain outlet
10. Differential pressure bypass valve
11. Air exhaust valve
12. Radiator and fan coil

13. Condensation hose
14. Hot water cylinder
15. City water

### Application 3

P20=2, Space heating mode ☀

P20=4, Space cooling mode ❄

P20=6, Space heating / cooling mode ☀ / ❄

Single circulation heating+ pool water pipeline connection diagram

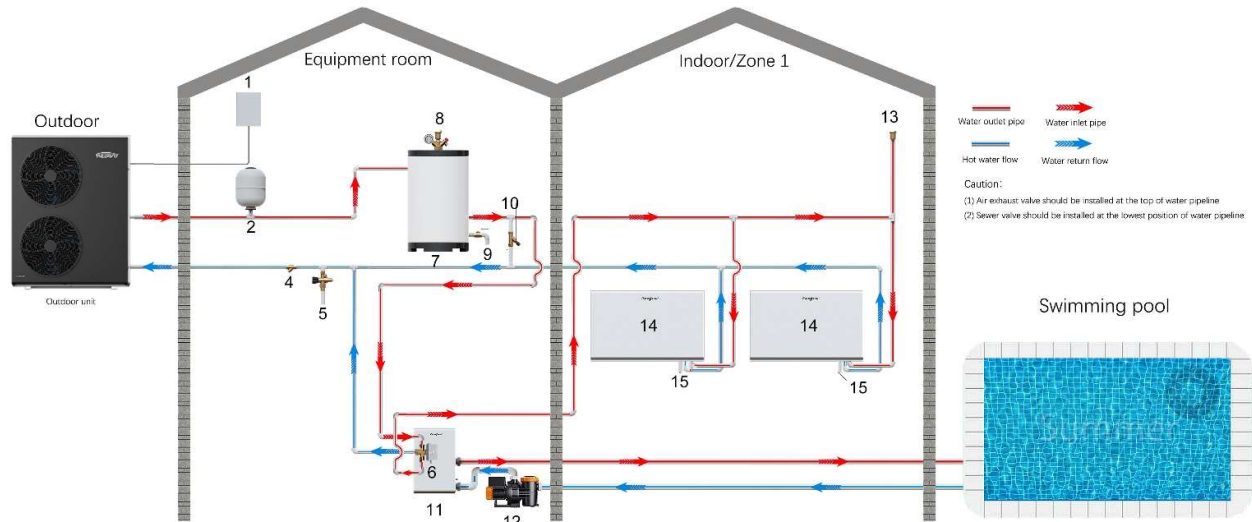

1. Electricity distribution box
2. Expansion vessel
3. Internal circulation water pump
4. Filter
5. Automatic water refill valve
6. 3 way electromagnetic valve
7. Buffer tank
8. Security device (Air release valve + Pressure gauge + Pressure release valve set)

9. Drain outlet
10. Differential pressure bypass valve
11. Heat exchanger for pool
12. Inverter water pump

13. Air exhaust valve
14. Radiator and fan coil
15. Condensation hose

## Application 4

P20=2, Space heating mode ☀

P20=4, Space cooling mode ❄

P20=6, Space heating / cooling mode ☀ / ❄

Single circulation heating+dual zones(floor heating)  
pipeline connection diagram

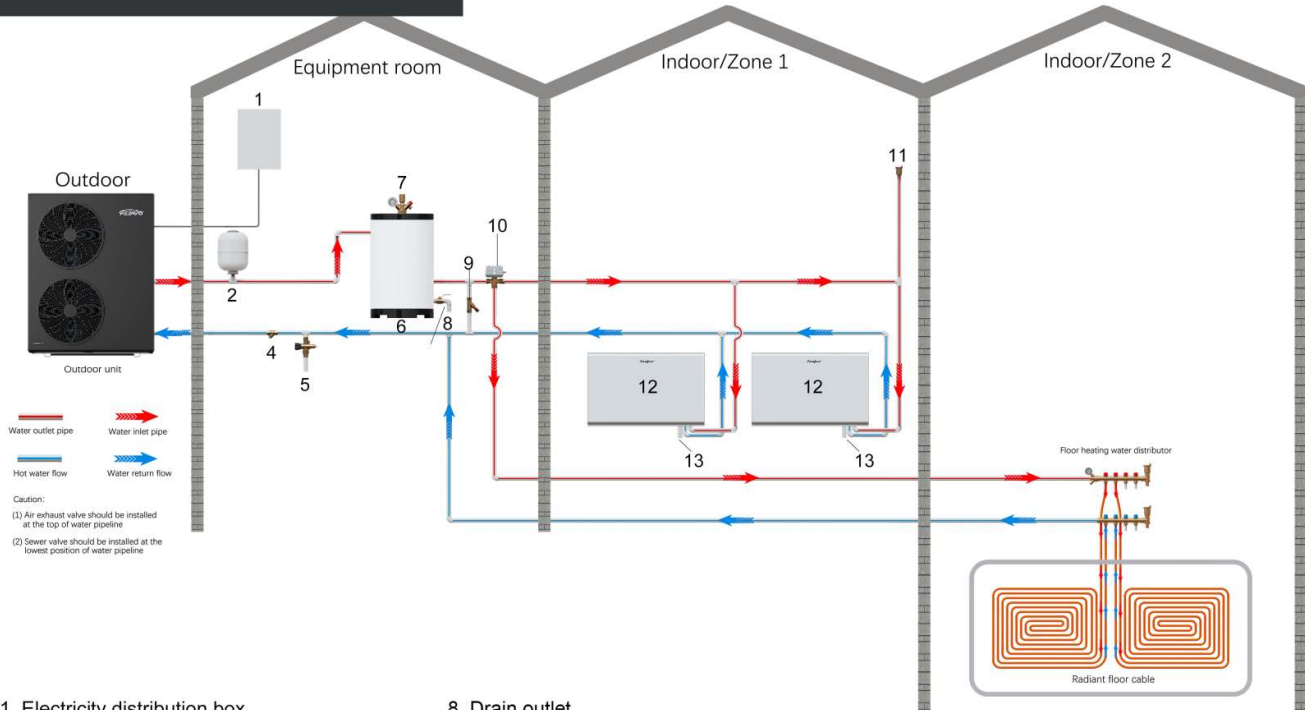

- |  |                                       |
|--|---------------------------------------|
| 1. Electricity distribution box  | 8. Drain outlet                       |
| 2. Expansion vessel  | 9. Differential pressure bypass valve |
| 3. Internal circulation water pump   | 10. 3 way electromagnetic valve       |
| 4. Filter  | 11. Air exhaust valve                 |
| 5. Automatic water refill valve  | 12. Radiator and fan coil             |
| 6. Buffer tank   | 13. Condensation hose                 |
| 7. Security device (Air release valve + Pressure gauge + Pressure release valve set) |                                       |

# Application 5

P20=7, Domestic water tank heating / space heating / cooling mode 

Single circulation heating+dual zones(floor heating) pipeline connection diagram

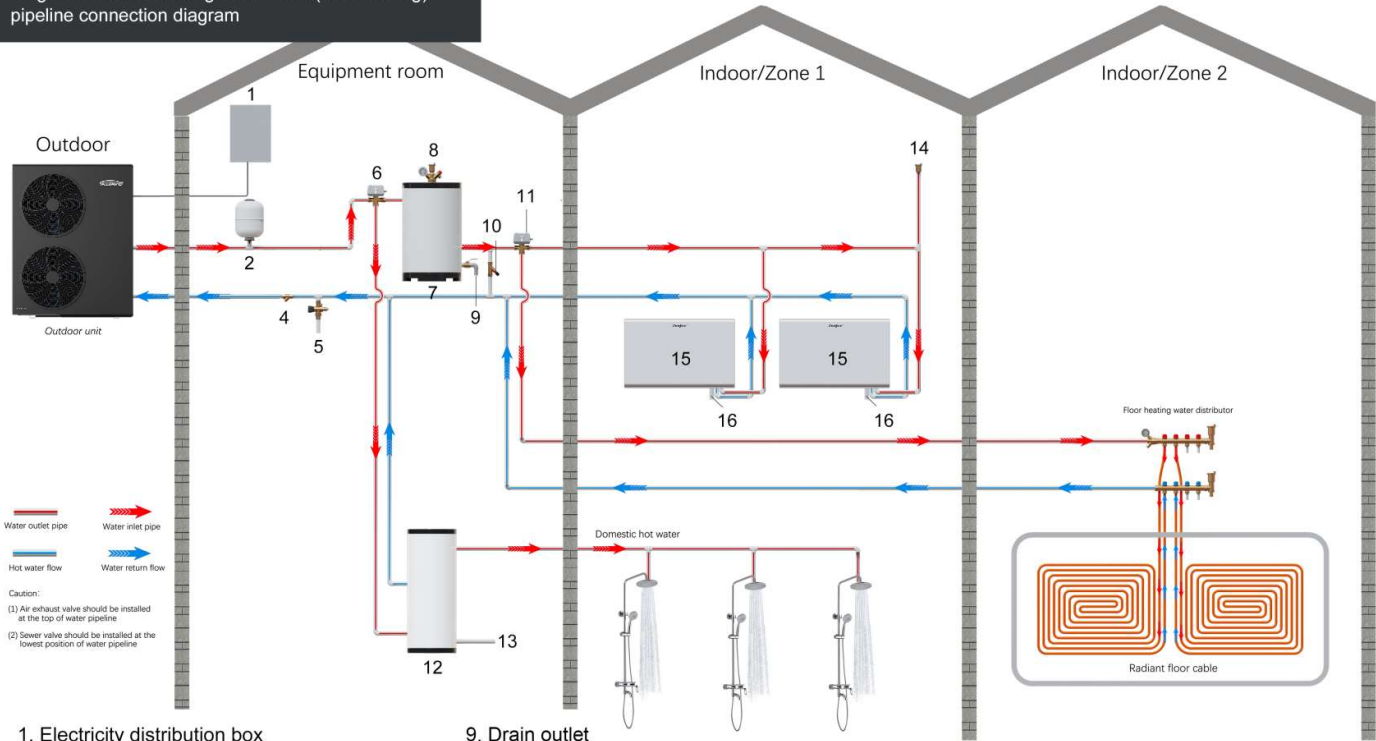

- 1. Electricity distribution box
- 2. Expansion vessel
- 3. Internal circulation water pump
- 4. Filter
- 5. Automatic water refill valve
- 6. 3 way electromagnetic valve
- 7. Buffer tank
- 8. Security device (Air release valve + Pressure gauge + Pressure release valve set)
- 9. Drain outlet
- 10. Differential pressure bypass valve
- 11. 3 way electromagnetic valve
- 12. Hot water cylinder
- 13. City water
- 14. Air exhaust valve
- 15. Radiator and fan coil
- 16. Condensation hose

Caution:  
 (1) Air exhaust valve should be installed at the top of water pipeline  
 (2) Sewer valve should be installed at the lowest position of water pipeline

## Application 6

P20=7, Domestic water tank heating / space heating / cooling mode 

Single circulation heating+dual zones(swimming pool)  
+hot water pipeline connection diagram

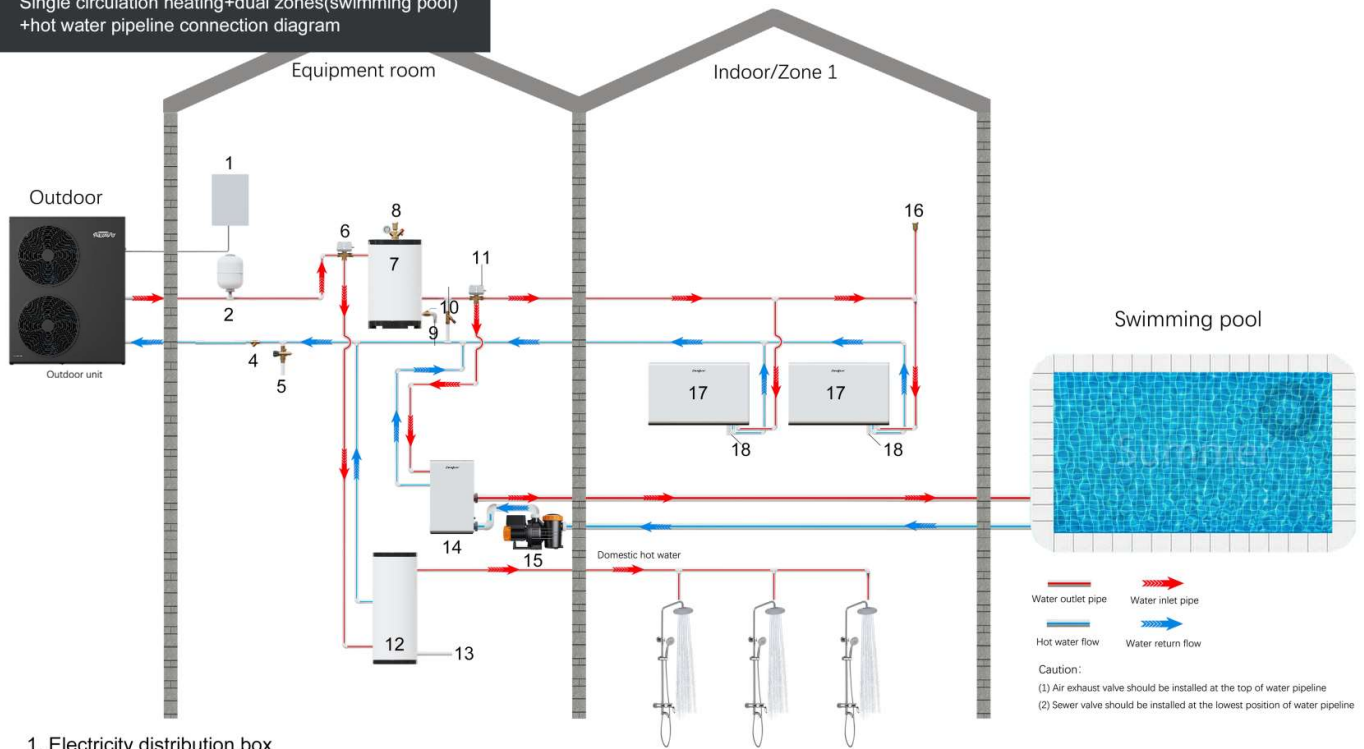

- |  |  |                             |
|--|--|-----------------------------|
| 1. Electricity distribution box  | 9. Drain outlet                        | 14. Heat exchanger for pool |
| 2. Expansion vessel  | 10. Differential pressure bypass valve | 15. Inverter water pump     |
| 3. Internal circulation water pump   | 11. 3 way electromagnetic valve        | 16. Air exhaust valve       |
| 4. Filter  | 12. Hot water cylinder                 | 17. Radiator and fan coil   |
| 5. Automatic water refill valve  | 13. City water                         | 18. Condensation hose       |
| 6. 3 way electromagnetic valve   |  |                             |
| 7. Buffer tank   |  |                             |
| 8. Security device (Air release valve + Pressure gauge + Pressure release valve set) |  |                             |

## Application 7

P20=2, Space heating mode ☀

P20=4, Space cooling mode ❄

P20=6, Space heating / cooling mode ☀ / ❄

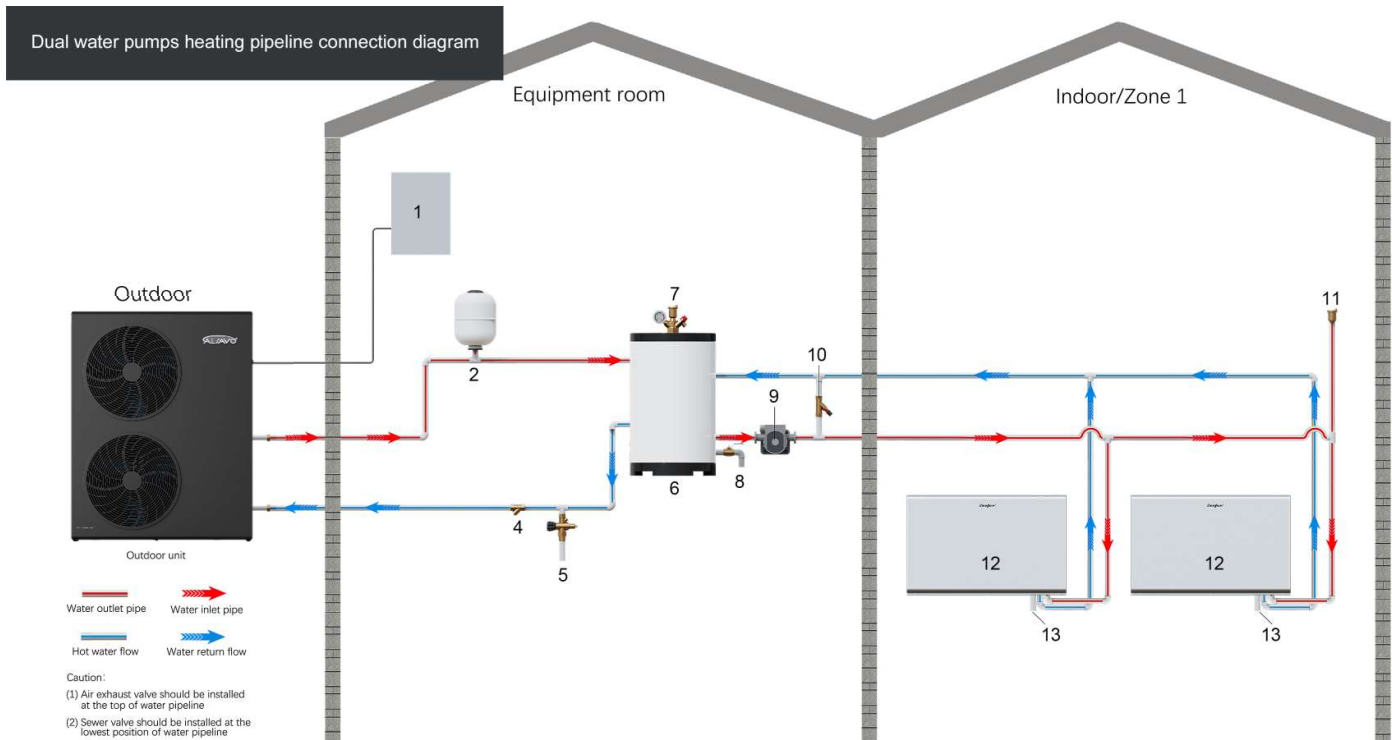

- |  |  |
|--|--|
| 1. Electricity distribution box  | 8. Drain outlet                        |
| 2. Expansion vessel  | 9. Circulation water pump              |
| 3. Internal circulation water pump   | 10. Differential pressure bypass valve |
| 4. Filter  | 11. Air exhaust valve                  |
| 5. Automatic water refill valve  | 12. Radiator and fan coil              |
| 6. Buffer tank   | 13. Condensation hose                  |
| 7. Security device (Air release valve + Pressure gauge + Pressure release valve set) |  |

# Application 8

P20=7, Domestic water tank heating / space heating / cooling mode 

Dual water pumps heating+hot water pipeline connection diagram

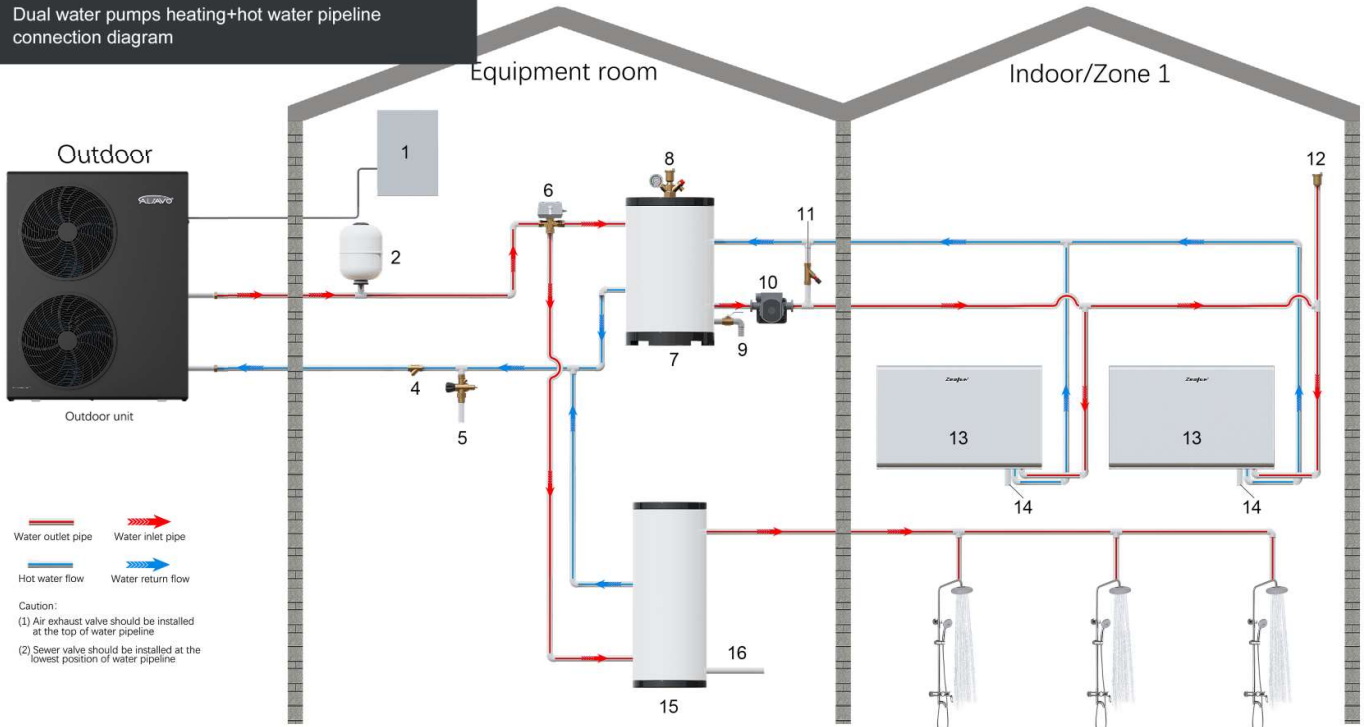

Caution:  
 (1) Air exhaust valve should be installed at the top of water pipeline  
 (2) Sewer valve should be installed at the lowest position of water pipeline.

- 1. Electricity distribution box
- 2. Expansion vessel
- 3. Internal circulation water pump
- 4. Filter
- 5. Automatic water refill valve
- 6. 3 way electromagnetic valve
- 7. Buffer tank
- 8. Security device (Air release valve + Pressure gauge + Pressure release valve set)
- 9. Drain outlet
- 10. Circulation water pump
- 11. Differential pressure bypass valve
- 12. Air exhaust valve
- 13. Radiator and fan coil
- 14. Condensation hose
- 15. Hot water cylinder
- 16. City water

## Application 9

P20=2, Space heating mode ☀️

P20=4, Space cooling mode ❄️

P20=6, Space heating / cooling mode ☀️ / ❄️

Dual water pumps heating+swimming pool  
water pipeline connection diagram

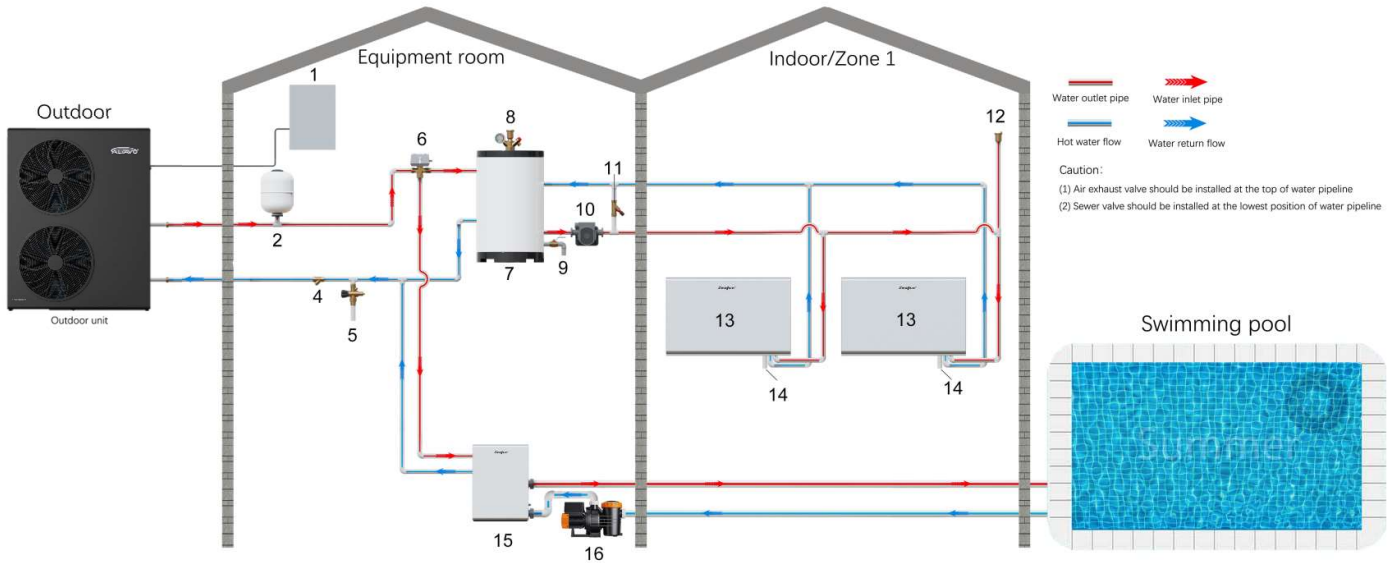

- |  |  |                             |
|--|--|-----------------------------|
| 1. Electricity distribution box  | 9. Drain outlet                        | 13. Radiator and fan coil   |
| 2. Expansion vessel  | 10. Circulation water pump             | 14. Condensation hose       |
| 3. Internal circulation water pump   | 11. Differential pressure bypass valve | 15. Heat exchanger for pool |
| 4. Filter  | 12. Air exhaust valve                  | 16. Inverter water pump     |
| 5. Automatic water refill valve  |  |                             |
| 6. 3 way electromagnetic valve   |  |                             |
| 7. Buffer tank   |  |                             |
| 8. Security device (Air release valve + Pressure gauge + Pressure release valve set) |  |                             |

# Application 10

P20=2, Space heating mode ☀

P20=4, Space cooling mode ❄

P20=6, Space heating / cooling mode ☀ / ❄

Dual water pumps heating+dual zones(floor heating) water pipeline connection diagram

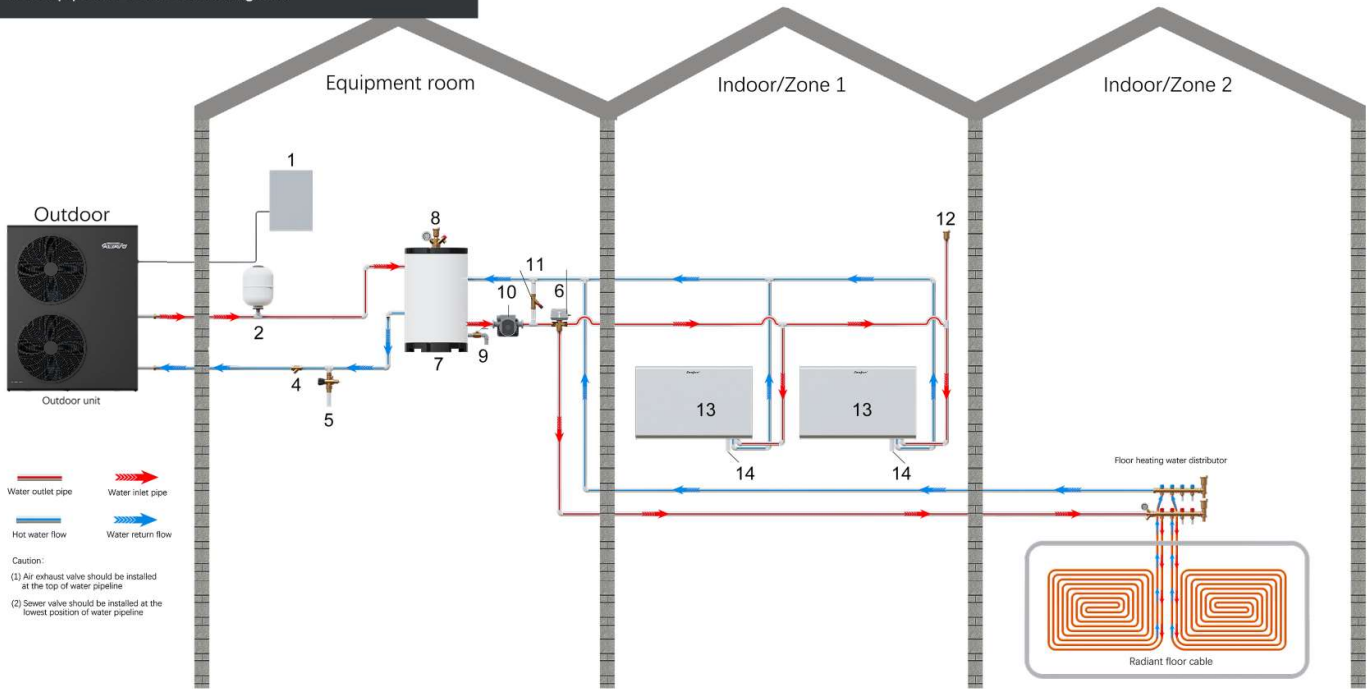

- 1. Electricity distribution box
- 2. Expansion vessel
- 3. Internal circulation water pump
- 4. Filter
- 5. Automatic water refill valve
- 6. 3 way electromagnetic valve
- 7. Buffer tank
- 8. Security device (Air release valve + Pressure gauge + Pressure release valve set)

- 9. Drain outlet
- 10. Circulation water pump
- 11. Differential pressure bypass valve
- 12. Air exhaust valve
- 13. Radiator and fan coil
- 14. Condensation hose

# Application 11

P20=7, Domestic water tank heating / space heating / cooling mode 

Dual water pumps heating+dual zones(floor heating)  
+hot water pipeline connection diagram

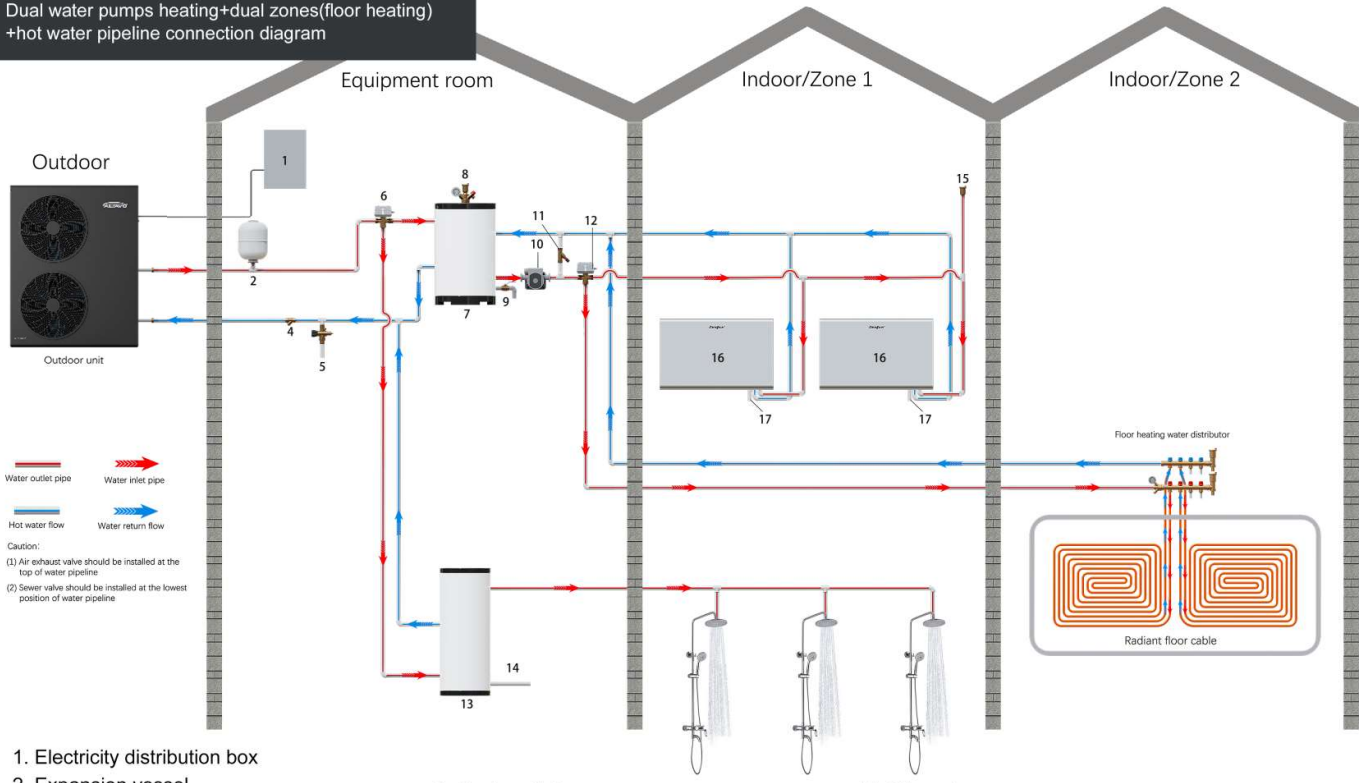

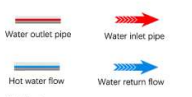
  
 Water outlet pipe (red line with arrow)  
 Water inlet pipe (blue line with arrow)  
 Hot water flow (red arrow)  
 Water return flow (blue arrow)

Caution:  
 (1) Air exhaust valve should be installed at the top of water pipeline.  
 (2) Sewer valve should be installed at the lowest position of water pipeline.

- |  |  |                           |
|--|--|---------------------------|
| 1. Electricity distribution box  | 9. Drain outlet                        | 14. City water            |
| 2. Expansion vessel  | 10. Circulation water pump             | 15. Air exhaust valve     |
| 3. Internal circulation water pump   | 11. Differential pressure bypass valve | 16. Radiator and fan coil |
| 4. Filter  | 12. 3 way electromagnetic valve        | 17. Condensation hose     |
| 5. Automatic water refill valve  | 13. Hot water cylinder                 |                           |
| 6. 3 way electromagnetic valve   |  |                           |
| 7. Buffer tank   |  |                           |
| 8. Security device (Air release valve + Pressure gauge + Pressure release valve set) |  |                           |

## Application 12

P20=7, Domestic water tank heating / space heating / cooling mode 

Dual water pumps heating+dual zones(swimming pool)  
hot water pipeline connection diagram

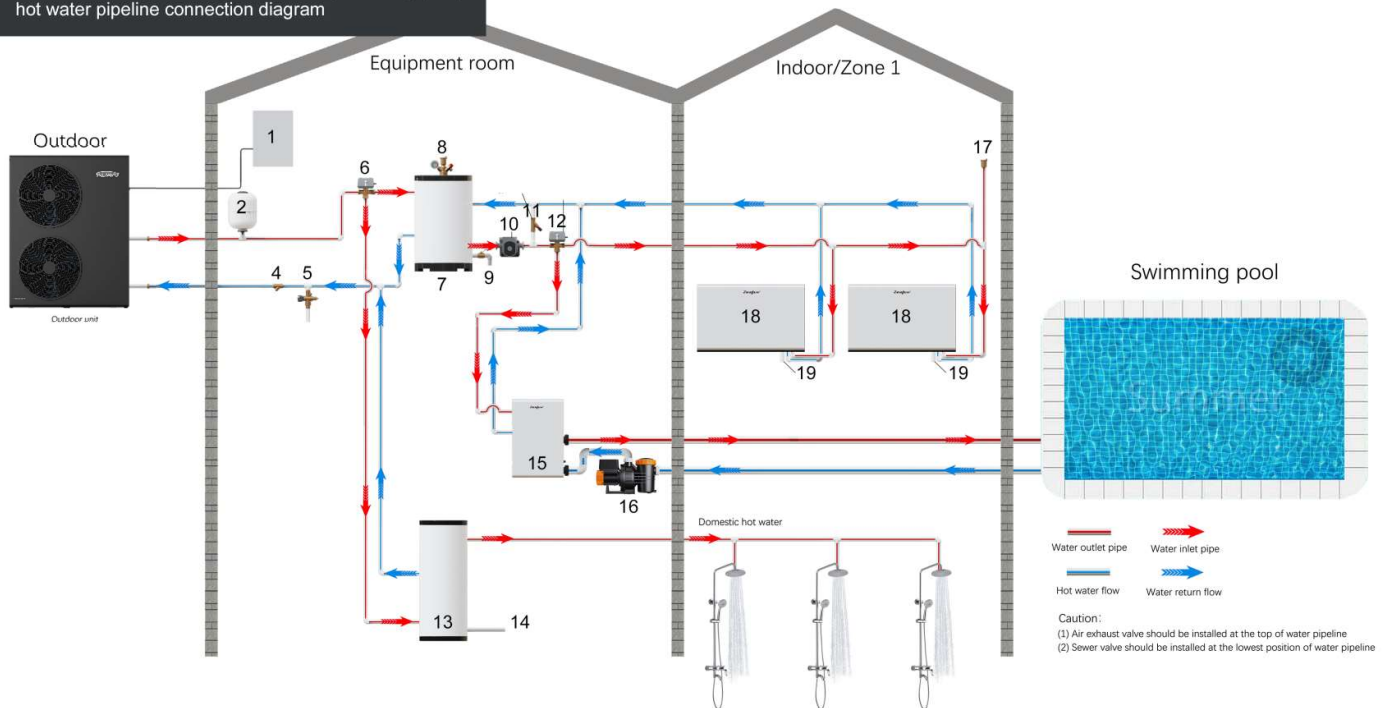

- |  |  |                             |
|--|--|-----------------------------|
| 1. Electricity distribution box  | 9. Drain outlet                        | 15. Heat exchanger for pool |
| 2. Expansion vessel  | 10. Circulation water pump             | 16. Inverter water pump     |
| 3. Internal circulation water pump   | 11. Differential pressure bypass valve | 17. Air exhaust valve       |
| 4. Filter  | 12. 3 way electromagnetic valve        | 18. Radiator and fan coil   |
| 5. Automatic water refill valve  | 13. Hot water cylinder                 | 19. Condensation hose       |
| 6. 3 way electromagnetic valve   | 14. City water                         |                             |
| 7. Buffer tank   |  |                             |
| 8. Security device (Air release valve + Pressure gauge + Pressure release valve set) |  |                             |

## 4.9 OPERATING LOGIC (PRIORITY MANAGEMENT)

When space heating and domestic water tank heating are needed at the same time, and required to set up different corresponding temperatures, domestic water tank is preferential heating. By setting the value of P1 (the temperature of domestic water tank) directly, when the temperature reaches set value + constant temperature difference, the heat pump stops the domestic water tank heating, and the three-way valve is automatically switched to start space heating.

On space heating state, the water temperature is controlled according to the P2 set value. If the terminal is a convector, the water inlet temperature controlled by the heat pump directly, and the zone target temperature required by the terminal devices. When the target zone environmental temperature is achieved, the two-pass valve will be closed, the water flow is cut off.



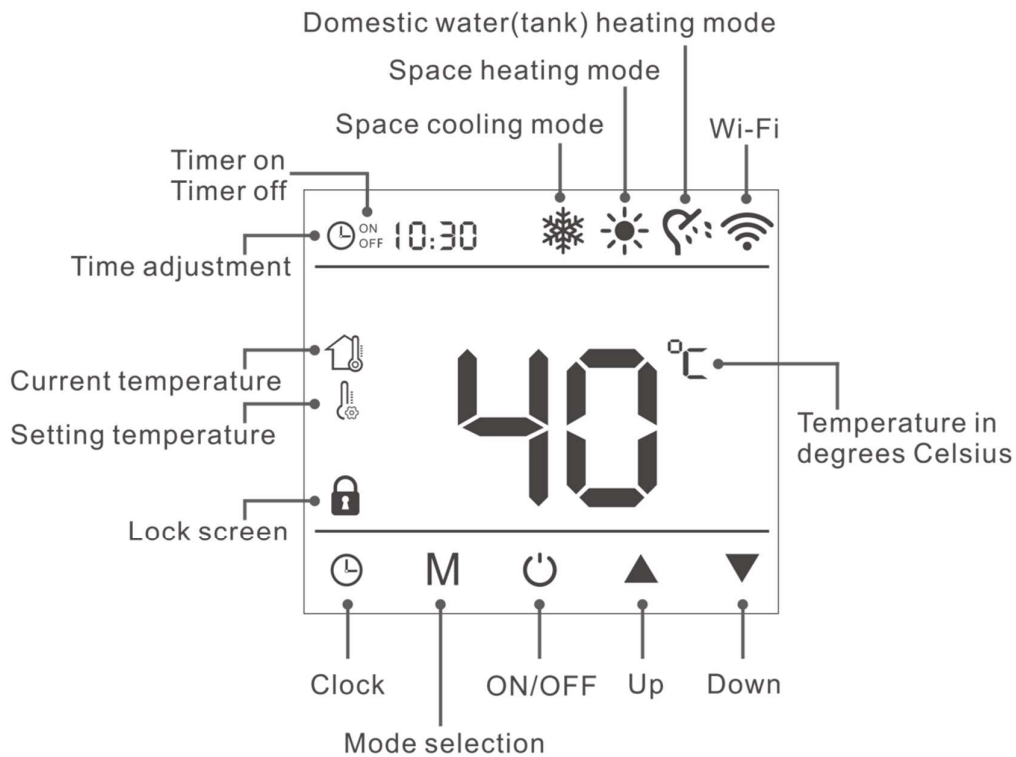





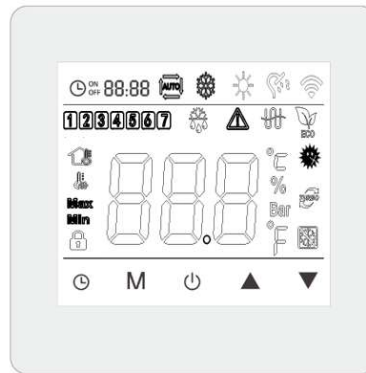



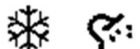

Parameter No.	Function Description	Optional range	Factory default
P1	Domestic water tank set temperature	20-50°C	45°C
P2	Water set temperature on heating mode	15-55°C	35°C



## 5 – CONTROLLEUR FUNCTION

### 5.1 Main function and icon introduction



Key icon	Description
	Space heating mode
	Space cooling mode
	Domestic water(tank) heating mode
	Space heating + Domestic water(tank) heating mode
	Space cooling + Domestic water(tank) heating mode
	Clock/Timer
	Time adjustment
	Timer on
	Timer off
	Temperature in degrees Celsius
	Lock screen
	Current temperature
	Setting temperature
	Wi-Fi

## ***Display function description***

- The screen will light up on first power up. After normal display, it will keep the state of the last power-off. The set temperature, actual temperature on the main interface will switch automatically along with the operation mode change.

- In the water tank mode, the tank set temperature and the tank real-time temperature will be displayed.

Use the up ▲ and down ▼ buttons in the main interface to adjust the tank set temperature.

- In the heating mode, the set temperature and the real-time temperature of the inlet water will be

displayed. Use the up ▲ and down ▼ buttons in the main interface to adjust the set temperature.

- In cooling mode, the set temperature and the real-time temperature of the inlet water are displayed.

Use the up ▲ and down ▼ buttons in the main interface to adjust the set temperature.

- In Space heating/cooling + Domestic water tank heating mode, the set temperature in space or water tank mode is displayed according to the actual operation mode, and the real-time temperature also displays the inlet water or water tank temperature according to the actual operation mode. In the power-

on main interface, you cannot use the up ▲ and down ▼ buttons to adjust the set temperature.

- Backlight When user press any button of the controller, the backlight turns on, if there is no operation within 1 minute, the backlight turns off.

**Note:** In Space heating/cooling + Domestic water tank heating mode, the temperature display area first shows the temperature of the water tank, and when it reaches the target temperature, the temperature display area shows the actual inlet water temperature.

## 5.2 Controller function

## On/Off Button

- Lock/unlock the screen.

The controller will automatically lock 30 seconds after no operation if there are no more movements.





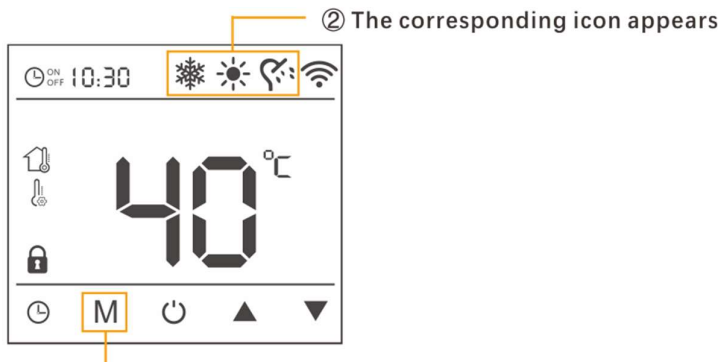

Long pressing to unlock the controller

## Mode selection

- Press **M** to change the operation mode.



① Press to change mode

- : Space heating mode (P20=2)
- : Space cooling mode (P20=4)
- : Domestic water tank heating mode (P20=1)
- : Space heating + Domestic water tank heating mode (P20=3)
- : Space cooling + Domestic water tank heating mode (P20=5)

- : Space heating/cooling mode + Domestic water tank heating mode (P20=7)

### **Temperature Adjustment**

Press the up ▲ and down ▼ to adjust the target temperature.

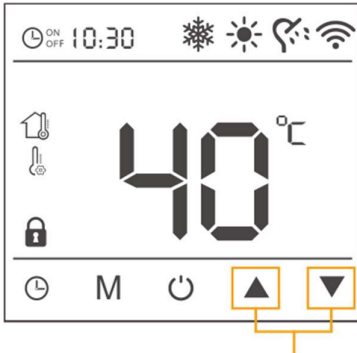

Short press to adjust the target temperature

### **On/Off**

Press ON/OFF button  to turn on or off the machine.



Short press turn on/off the machine

### **Adjusting the heating temperature (direct heating)**

In the water tank mode, it displays the set temperature of the water tank and the real-time temperature of the water tank. In the main interface, use the ▲ and ▼ to set the set temperature of the water tank.

In heating mode, it displays the set temperature and real-time return water temperature. In the main interface, use the ▲ and ▼ keys to adjust the set temperature.

In cooling mode, it displays the return water set temperature and the real-time return water temperature. In the main interface, use the ▲ and ▼ keys to adjust the set temperature.

In the automatic mode, the set temperature in the room or water tank mode is displayed according to the actual operation mode, and the real-time temperature also displays the return water or water tank temperature according to the actual operation mode. Do not use the ▲ and ▼ keys to adjust the set temperature in the main interface of starting up.

Zone Thermostat Setting (Adjust directly on the controller of the fan coil or the controller of the mixing valve)

### Parameters Button

Long press ⌚ and ▲ for 3 seconds to enter parameter setting, press ▲ and ▼ to select P value, press ⌚ to enter P value setting. Using ▲ and ▼ to change the setting.

### Viewing and setting parameters P

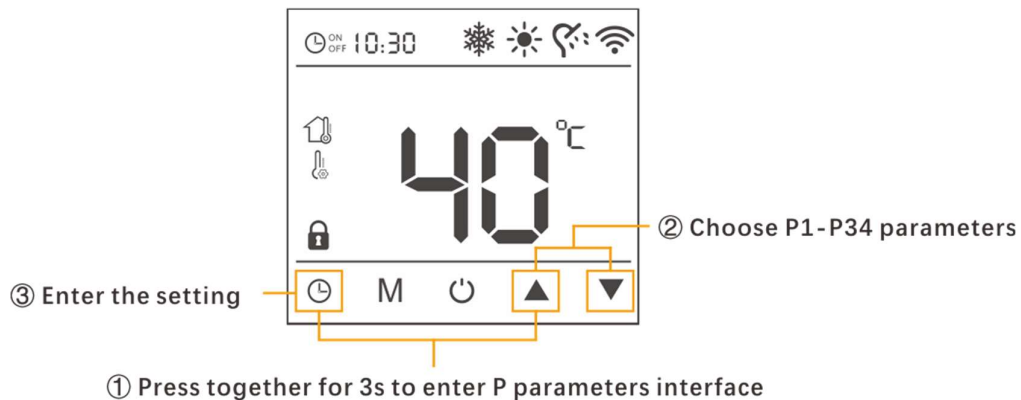







### - Resetting parameters

Press and hold the up ▲ and down ▼ buttons at the same time. When you hear a beep, the settings are reset and the default values are displayed.

### Setting parameters

➤ Hot water tank temperature setting

Long press  and  for 3 seconds to enter parameter setting, press  and  to select P value, press  to enter P value setting. Using  and  to change the setting.

Parameter	Function Description	Optional range	Factory default
P1	Domestic water tank set temperature	20-50°C	45°C
P4	Domestic water tank heating start hysteresis	3-15°C	5°C

### ***Mandatory defrosting***

These icons displays in space heating mode

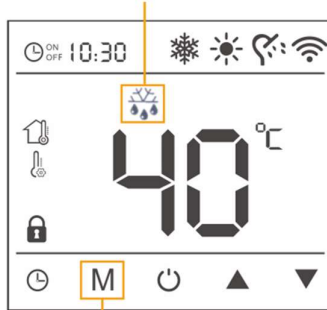

Long press for 3s under controller on state and heating mode

Press and hold the mode selection button **M** for 3 seconds under the on state of the controller and heating mode to enter the mandatory defrosting process.



## Timer setting

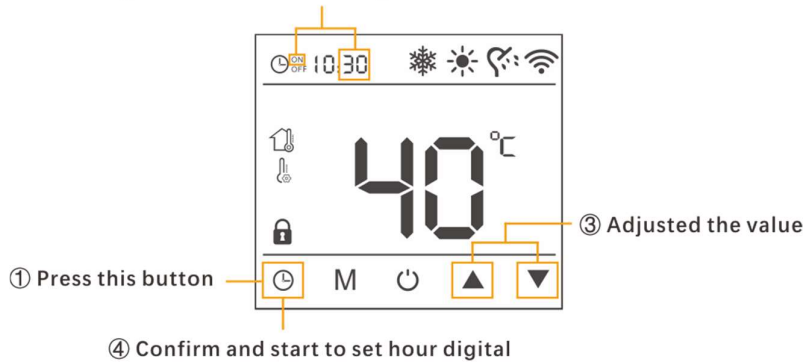

② ON icon and minute digital flashes

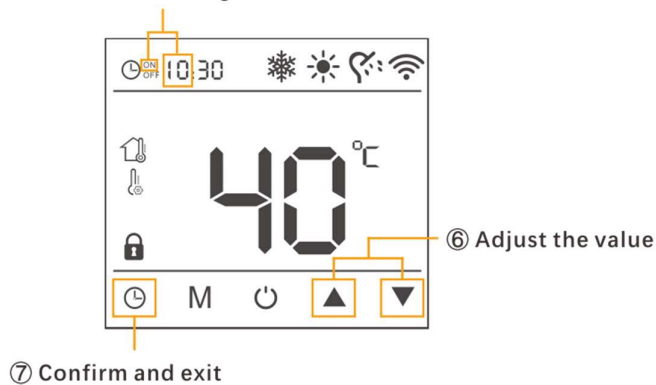

⑤ ON icon and hour digital flashes



After setting the timer on time, press the clock button  to display the last set timer off time, the timer off icon  flashes, same way to set the timer off time as setting timer on time.

**Note:** The timer setting will be automatically determined, and the timer adjustment state will be exited 10 seconds after no operation and then the timer on icon  and timer off icon  will be always on.

### Cancel the timer setting



Cancel timing settings by restarting the line controller

A confirm timer setting can be canceled by press the ON/OFF button  in the unlocked state of the controller.

### 5.3 Setting of the heating (target temperature)

#### 5.3.1 Recommended Setting Temperature for Terminal Equipment

Equipment	Suggest setting temperature
Floor heating	30°C
Fan coil	40°C
Heating radiator	50°C

#### 5.3.2 Weather Compensation Mode

##### **Weather Compensation Mode Introduction**

This mode automatically adjusts the target water inlet temperature of the unit according to the change of the outdoor ambient temperature in the heating mode. The lower the outdoor ambient temperature is, the higher the target water inlet temperature is set (up to 55°C); the higher the outdoor ambient temperature is, the lower the target water inlet temperature is set (when the outdoor ambient temperature is 18°C, the target water inlet temperature is 18°C).

##### **ON/OFF of the Weather Compensation Mode**

Set through the line controller parameter P23, when P23=1, the weather compensation mode is on; when P23=0, the weather compensation mode is off. (Default value P23=1, i.e. weather compensation mode is on by default)

Weather Compensation Operating Logic

$$T_s = \frac{P25 - 18}{28} * (18 - T_{out}) + 18 + P24$$

- Formula code parsing:
- Ts: Target temperature under weather compensation mode(maximum limit 55°C)

P25: Curve adjustment parameter 2, adjustment range: 30~45°C, default: 30°C

P24: Curve adjustment parameter 1, adjustment range: 0~10°C, default: 0°C

Tout: Ambient temperature(measured value, round figure)

P24+P25 \ Tout	-10	-7	2	7	12	16	18
20	20.0	19.8	19.1	18.8	18.4	18.1	18.0
21	21.0	20.7	19.7	19.2	18.6	18.2	18.0
22	22.0	21.6	20.3	19.6	18.9	18.3	18.0
23	23.0	22.5	20.9	20.0	19.1	18.4	18.0
24	24.0	23.4	21.4	20.4	19.3	18.4	18.0
25	25.0	24.3	22.0	20.8	19.5	18.5	18.0
26	26.0	25.1	22.6	21.1	19.7	18.6	18.0
27	27.0	26.0	23.1	21.5	19.9	18.6	18.0
28	28.0	26.9	23.7	21.9	20.1	18.7	18.0
29	29.0	27.8	24.3	22.3	20.4	18.8	18.0
30	30.0	28.7	24.9	22.7	20.6	18.9	18.0
31	31.0	29.6	25.4	23.1	20.8	18.9	18.0
32	32.0	30.5	26.0	23.5	21.0	19.0	18.0
33	33.0	31.4	26.6	23.9	21.2	19.1	18.0
34	34.0	32.3	27.1	24.3	21.4	19.1	18.0
35	35.0	33.2	27.7	24.7	21.6	19.2	18.0
36	36.0	34.1	28.3	25.1	21.9	19.3	18.0
37	37.0	35.0	28.9	25.5	22.1	19.4	18.0
38	38.0	35.9	29.4	25.9	22.3	19.4	18.0
39	39.0	36.8	30.0	26.3	22.5	19.5	18.0
40	40.0	37.6	30.6	26.6	22.7	19.6	18.0
41	41.0	38.5	31.1	27.0	22.9	19.6	18.0
42	42.0	39.4	31.7	27.4	23.1	19.7	18.0
43	43.0	40.3	32.3	27.8	23.4	19.8	18.0
44	44.0	41.2	32.9	28.2	23.6	19.9	18.0
45	45.0	42.1	33.4	28.6	23.8	19.9	18.0
46	46.0	43.0	34.0	29.0	24.0	20.0	18.0
47	47.0	43.9	34.6	29.4	24.2	20.1	18.0
48	48.0	44.8	35.1	29.8	24.4	20.1	18.0
49	49.0	45.7	35.7	30.2	24.6	20.2	18.0
50	50.0	46.6	36.3	30.6	24.9	20.3	18.0
51	51.0	47.5	36.9	31.0	25.1	20.4	18.0
52	52.0	48.4	37.4	31.4	25.3	20.4	18.0
53	53.0	49.3	38.0	31.8	25.5	20.5	18.0
54	54.0	50.1	38.6	32.1	25.7	20.6	18.0
55	55.0	51.0	39.1	32.5	25.9	20.6	18.0

➤ **Examples of Applications of Weather Compensation Mode**

When P25 is set to 30 and P24 to 0, the target water inlet temperature is set to 30°C under the -10°C ambient temperature correspondence, and the corresponding target water inlet temperature is 18°C at 18°C ambient temperature, which is highly energy efficient and the comprehensive energy efficiency is close to A+++.

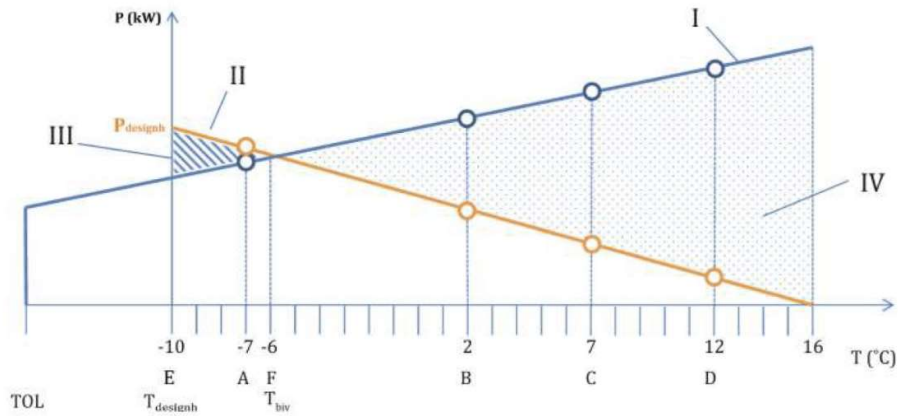

### Direct Heating Mode

P23 parameter is set to 0 (weather compensation mode is off), user can adjust the target inlet water temperature by pressing the "up" and "down" buttons directly from the controller.

#### 5.4 Setting of the DHW tank heating (electric mode)

DHW Tank Settings

DHW Tank Electric Heating Settings

Long press and for 3 seconds to enter parameter setting, press and to select P value, press to enter P value setting. Using and to change the setting.

Parameter	Function Description	Optional range	Factory default
P8	Electric heating start temperature	-30~15°C	-7°C
P9	Start time in electric heating does not heat up	2-90 minutes	30 minutes

#### 5.5 Setting of the DHW tank heating (domestic water)

DHW Tank Heating Priority Settings

When P20=1, 3, 5, 7, it is DHW tank heating priority.

DHW Tank Reheating Temperature and Maximum Heating Time Settings

Parameter	Function Description	Optional range	Factory default
P4	Water tank heating start hysteresis	3-15°C	5°C

#### 5.6 Setting of the sterilization mode DHW tank heating (domestic water)

## Water Tank High Temperature Sterilization Function

### ➤ Motion Activation

- ① The first time it is enabled, each time the unit is powered up and recognises that P32 is a non-zero value, it is programmed to set d40 to 1 once and to select a sterilisation operating period close to the current point in time to heat the tank temperature (achieved through the output of the relay controlling the electric heating of the tank) to 75°C once.
- ② When the water tank is heated to 75°C, end the last timer and restart the timer (d40=P32); when the countdown of the day (d40 can be checked) is 1 and the sterilisation operation period is reached, perform the water tank temperature heating to 75°C once.

### ➤ Motion Completion

When the unit identifies that the temperature of the water tank is  $\geq 75^{\circ}\text{C}$  (parameter adjustable), the relay stops the output, completes the sterilisation function of the current time, and enters the next sterilisation cycle timing.

## Corresponding Controller Parameters

Controller Parameters	Parameters Explanation	Adjustment Range	Unit	Default Value	Minimum Adjustment Value	Remark
P32	Sterilisation function cycle days setting	0-30	Day	14	$\pm 1$	When set to 0, the sterilisation function does not run; When set to 1, the sterilisation function runs on a daily cycle.
P33	Sterilisation runtime	0-23	Hour	1	$\pm 1$	When set to 1, means that the water tank heat by using the water tank electric heating from 1:00 a.m., and ends when the water tank temperature reaches 75°C, and enters the next timing cycle
P34	Sterilisation target water temperature setting	60-75	°C	65	$\pm 1$	
d40	Sterilisation countdown days	30-0	Day	P21 set value	Decreasing by 1 per day	

### Notes:

- During the process of heating with the water tank electric heating, the "💡" icon on the controller flashes, indicating that the target water temperature of the water tank is being heated up to 75°C; until the heating process is finished, the "💡" icon turns into a normally lit state.
- The sterilisation function is not performed when the tank temperature sensor is faulty.

## 5.7 Parameters data

### Parameters Setting

#### 1/ P Parameter viewing and setting

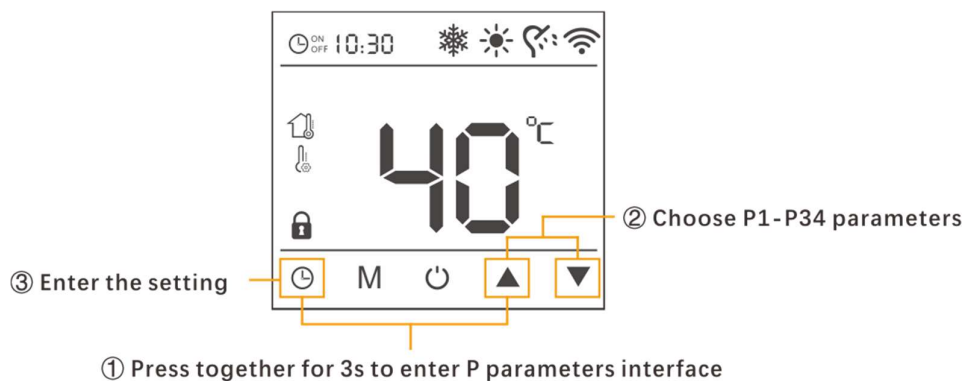

#### 2/ Parameter reset

Press and hold the up ▲ and down ▼ buttons at the same time, when beep sound is heard, the parameters are reset and the default values are displayed.

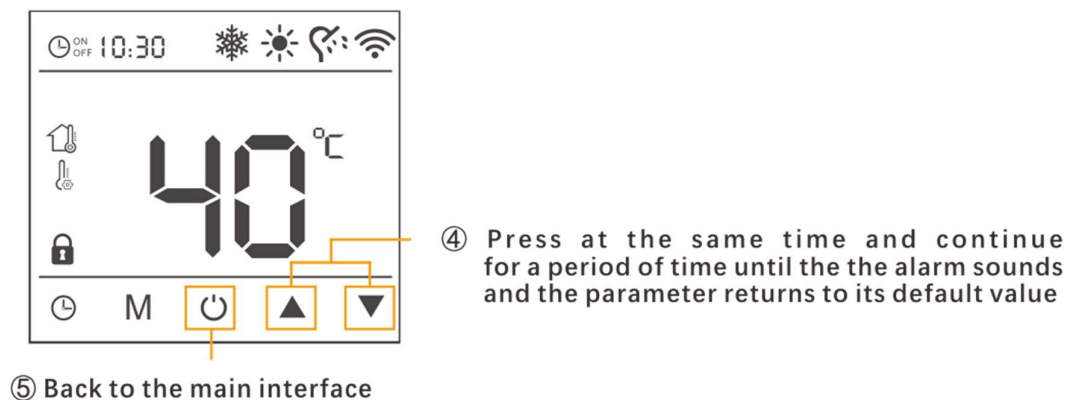

## Parameters

Parameter	Function Description	Optional range	Factory default
P1	Domestic water tank set temperature	20 ~ 50°C	45°C
P2	Space heating mode set temperature	15-55°C	35°C
P3	Space cooling mode set temperature	12-35°C	12°C
P4	Water tank heating start hysteresis	3-15°C	5°C
P5	Space mode start hysteresis	2-15°C	3°C
P6	Constant temperature difference (set the difference value between the set temperature and the actual temperature when the constant temperature is started)	0-6°C	2°C
P7	Electric heating on and off settings in space heating mode	0: Controlled by P9 setting 1: Close 2: Controlled by P8 setting	0
P8	Electric heating start temperature	-30~15°C	-7°C
P9	Start time in electric heating does not heat up	2-90 minutes	30 minutes
P10	Maximum floor water outlet temperature in space heating	(MAX.TEMP) 25-67°C	65°C
P11	Critical temperature for the outdoor ambient temperature to be too low	-40-0°C	-15°C
P12	Defrost mode	0: Smart defrost/ 1: periodical defrost	1
P13	Defrost temperature setting	-15-2°C	-4°C
P14	Defrost exit temperature setting	8-30°C	15°C
P15	Defrost program interval	25-70 minutes	40 minutes
P16	Duration of defrosting process	2-20 minutes	12 minutes
P17	Tank temperature compensation	-10-10°C	-2°C
P18	Temperature compensation of outlet and inlet water	-10-10°C	0°C
P19	Pump control when reach target temperature in space mode	0: Always on/ 1: Turn on the water pump at intervals after reaching the target temperature	0
P20	Model parameter selection: 1: Domestic water tank mode	1; 2; 3; 4; 5; 6; 7	2

	2: Space heating mode 3: Domestic water tank heating and space heating mode 4: Space cooling mode 5: Domestic water tank heating and space cooling mode 6: Space heating or cooling mode 7: Domestic water tank heating and space heating or cooling mode		
P21	Turn on the pump manually, only valid in off state of the controller	0: off 1: Turn on the water pump forcibly	Power on or switch off the machine to release the settings
P22	Phase sequence protection	0 ~ 1 (0: off, 1: on)	0
P23	Weather compensation mode ON/OFF	0 ~ 1 (0: off, 1: on)	1
P24	Curve adjustment parameter 1	0 ~ 10°C	0°C
P25	Curve adjustment parameter 2	30 ~ 45°C	30°C
P26	Heating types	0: ECO mode 1: Powerful mode 2: Turbo mode	0
P27	Maximum frequency limit for pool heating	30 ~ 100Hz	75
P28	Pool heating return air superheat temperature	-10 ~ 10°C	3°C
P29	Power compensation value	-40 ~ 200(*10W)	20
P30	Water flow rate setting	0.1 ~ 5.0 m3/H	1.2
P31	Correction parameter for temperature difference between inlet and outlet water	-9.9 ~ 9.9°C	0.0°C
P32	Sterilization function cycle days setting	0 ~ 30 days	14 days
P33	Sterilization runtime	0 ~ 23 hours	1 hour
P34	Sterilization target water temperature setting	60 ~ 75°C	65°C

## Parameters Checking

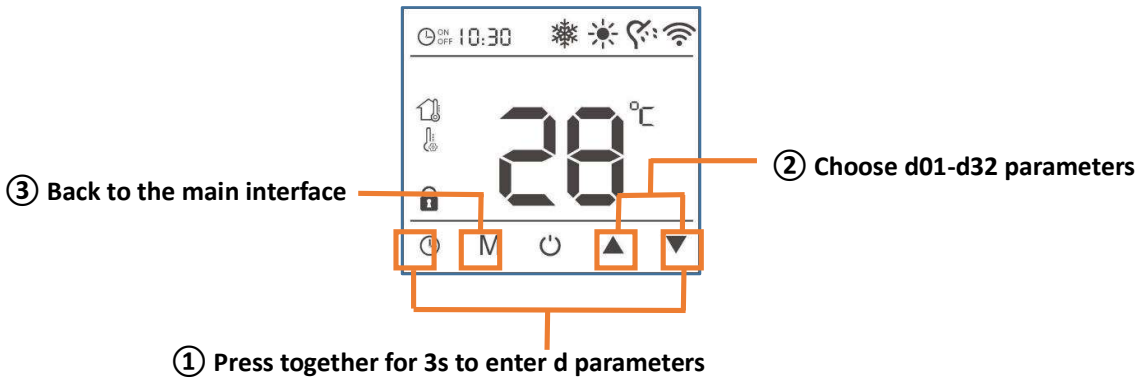

Parameter	Description
d01	Frequency
d02	Current
d03	Water in temperature
d04	Domestic tank temperature
d05	Water pipe temperature
d06	/
d07	Exhaust temperature
d08	Ambient temperature
d09	Evaporator temperature
d10	Return temperature
d11	Temperature after throttling
d12	Electronic expansion valve opening (displayed as actual opening angle)
d13	Protection code
d14	Shutdown code
d15	Shutdown time (last shutdown time, minutes)
d16	Outdoor fan speed (actual value*10)
d17	Target frequency
d18	EVI electronic expansion valve opening (displayed as actual opening angle)
d19	IPM module temperature
d20	WIFI connection status: 0, 1, 6: configuration status; 2: configured; 3: connected to the router;

	4: connected to the cloud; 5: low power mode
d21	Economizer inlet temperature
d22	Economizer outlet temperature
d23	/
d24	/
d25	Operating hours
d26	Operating days
d27	DC voltage
d28	AC input voltage
d29	Fan motor output power
d30	Compressor phase voltage
d31	Compressor phase current
d32	Remote signal strength

### ***Memory function***

The controller can memorize the on-off state, operation mode, parameter setting, the time of timer and clock. When the on-off state, operation mode, parameter setting and timing time are changed for 2 seconds, the controller will start to rewrite the EEPROM and store the data, the controller will process the state according to the last power outage.

Note: The controller will not memorize the functions setting of refrigerant recovery, mandatory defrosting, and manual water pump opening.

## 6 – TROUBLESHOOTING

<b>Error code</b>	<b>Description</b>	<b>Solution</b>
E01	PCB/Controller EEPROM error	<ol style="list-style-type: none"> <li>1. Re-connect to the power and restart</li> <li>2. Replace the controller</li> <li>3. Replace the PCB</li> </ol>
E02	Water cylinder temp sensor error	<ol style="list-style-type: none"> <li>1. Check the wiring of the sensor and terminal</li> <li>2. Replace the sensor</li> </ol>
E03	Water supply temp sensor error	<ol style="list-style-type: none"> <li>1. Check the wiring of the sensor and terminal</li> <li>2. Replace the sensor</li> </ol>
E04	Return water temp sensor error	<ol style="list-style-type: none"> <li>1. Check the connection of the sensor and terminal</li> <li>2. Replace the sensor</li> </ol>
E05	Evaporator temp sensor error	<ol style="list-style-type: none"> <li>1. Check the connection of the sensor and terminal</li> <li>2. Replace the sensor</li> </ol>
E06	Ambient temp sensor error	<ol style="list-style-type: none"> <li>1. Check the connection of the sensor and terminal</li> <li>2. Replace the sensor</li> </ol>
E07	Compressor exhaust temp sensor error	<ol style="list-style-type: none"> <li>1. Check the connection of the sensor and terminal</li> <li>2. Replace the sensor</li> </ol>
E08	PCB/Controller communication error	<ol style="list-style-type: none"> <li>1. Check if the signal cable disconnect</li> <li>2. Replace the signal cable</li> <li>3. Replace the controller</li> <li>4. Replace the PCB</li> </ol>
E09	/	/
E10	/	/
E11	Over current protection	<ol style="list-style-type: none"> <li>1. Check the fan motor output</li> <li>2. Check the driver board if burned or not</li> <li>3. Check the compressor earth line</li> <li>4. Replace the driver board</li> </ol>
E12	PCB module error	Replace the PCB
E13	High voltage/Low voltage protection	Check the voltage
E14	Water flow protection	<ol style="list-style-type: none"> <li>1. Water system stuck or not vacuumed, check the water system</li> <li>2. Water flow switch failed, replace with a new one</li> <li>3. Water pump failed, replace with a new one</li> </ol>
E15	System high pressure protection	<p>If appear when start the hp,</p> <ol style="list-style-type: none"> <li>1. replace the PCB</li> <li>2. replace the high pressure switch</li> </ol>

		If appear during running, please check, 1. if the ventilation is OK 2. if the water flow is sufficient
E19	Return temp sensor error	1. Check the wiring of the sensor and terminal 2. Replace the sensor
E20	Throttling temp sensor error	1. Check the wiring of the sensor and terminal 2. Replace the sensor
E21	High water temp protection in heating mode	Measure the real water out water temp to see if over the protection value. 1. Replace the temp sensor 2. Replace the PCB
E22	Low water temp protection in cooling mode	Measure the real water out water temp to see if over the protection value. 1. Replace the temp sensor 2. Replace the PCB
E23	Excessive temperature difference between inlet and outlet water protection	Measure the real water out water temp to see if over the protection value. 1. Replace the temp sensor 2. Replace the PCB
E24	/	/
E25	Anti frozen protection	Disappear when ambient temp rise up
E26	PCB/Driver board communication error	Replace the PCB
E27	System low pressure protection	1. Check the pressure gauge 2. Refill the gas to rated amount
E28	High exhaust temp protection	1. Check the water pump if normal running 2. Check the water flow is sufficient 3. Check the connection of water flow switch terminal 4. Replace the water flow switch
E29	Evaporator high temp protection in cooling mode	1. Check the ventilation 2. Check the fan speed 3. Replace the temp sensor 4. Replace the PCB
E30	Low ambient temp protection	Disappear when ambient temp rise up
E31	No.1 fan motor error	Fan motor stuck or failed, replace the fan motor
E33	Compressor fail to start error	1. Replace the compressor 2. Replace the PCB
E34	Compressor speed feedback error	1. Replace the compressor 2. Replace the PCB
E35	/	/

E36	IPM high temp protection	1. Check if high ambient temp 2. Check if low air volume
E37	Compressor over current protection	1. Check the water flow 2. Check the gas system if stuck
E38	U-phase over current protection	1. Check the compressor wires connection 2. Replace the compressor
E39	V-phase over current protection	1. Check the compressor wires connection 2. Replace the compressor
E40	W-phase over current protection	1. Check the compressor wires connection 2. Replace the compressor
E41	DC over voltage protection	1. Check the power supply 2. Replace the PCB
E42	DC under voltage protection	1. Check the power supply 2. Replace the PCB
E43	U-phase error protection	Check the compressor wiring
E44	V-phase error protection	Check the compressor wiring
E45	W-phase error protection	Check the compressor wiring
E46	U-phase offset fault	Check the compressor wiring
E47	V-phase offset fault	Check the compressor wiring
E48	W-phase offset fault	Check the compressor wiring
E49	Compressor stall error	1. Check the compressor terminal 2. Replace the driver board 3. Replace the compressor
E50	Compressor speed abnormal protection	1. Check if the compressor fail 2. Replace the driver board
E51	Compressor stuck error	1. Re-connect to the power and restart 2. Replace the compressor
E52	PFC over current protection	Replace the PCB
E53	PFC over voltage protection	Replace the PCB
E54	PFC over voltage protection	Replace the PCB
E55	PFC error	Replace the PCB
E56	Economizer inlet temp sensor error	1. Check the connection of the sensor and terminal 2. Replace the sensor
E57	Economizer outlet temp sensor error	1. Check the connection of the sensor and terminal 2. Replace the sensor
E58	PFC data loading error	1. Re-connect to the power and restart 2. Replace the PCB
E59	Driver data loading error	1. Re-connect to the power and restart

		2. Replace the PCB
E60	DC voltage feedback over voltage protection	1. Re-connect to the power and restart 2. Replace the PCB
E64	Driver communication disconnect	1. Re-connect to the power and restart 2. Replace the PCB
E65	Driver execution overload	1. Re-connect to the power and restart 2. Replace the PCB
E94	Reserved	/
E95	NO.2 fan motor error	Fan motor stuck or failed, replace the fan motor
E96	Reserved	/
E97	Reserved	/
E98	Reserved	/
E99	Reserved	/

## 7 – APP CONNECTION

### Synchronization of the WIFI module



Press simultaneously for 3s to enter the WIFI pairing state.

Press and hold the combination button **M+▼** for 3 seconds at the same time to enter the WIFI and router pairing, the WIFI icon flashes , add the device via TUYA APP on your phone.

If the addition is not successful within 3 minutes, the controller will automatically exit the pairing. Once the heat pump is successfully added and connected, the WIFI icon  will always be on.

#### 7.1 TUYA WIFI APP "Download"

Download "TUYA" APP from GOOGLE PLAY for Android or APP STORE for iPhone.



#### 7.2 Connection

Make sure your smart phone is under 2.4 GHz wireless network signal and your heat pump device is on to use TUYA and follow instruction as below.

7.2.1 Keep pressing the mode selection button **M** and down **▼** buttons on the control panel until you see the WIFI icon  is flicking, that means the heat pump is waiting for the connection of WIFI.

7.2.2 Press "Add Device", and the heat pump will auto detected by the app, then please add your heat pump device.

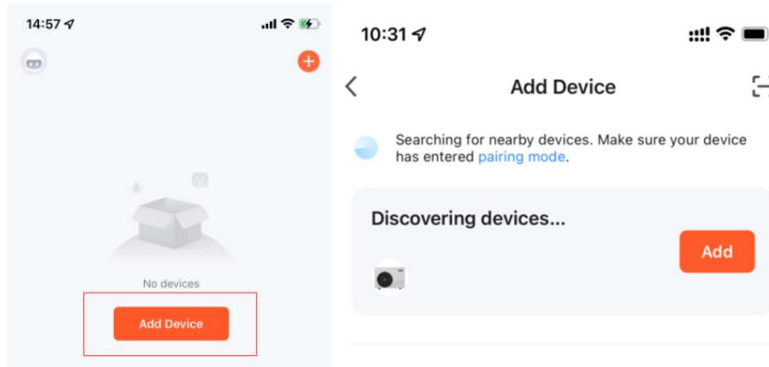

Select 2.4 GHz WIFI Network and enter password. If your device is on, press Next directly, and it will connect the heat pump successfully.

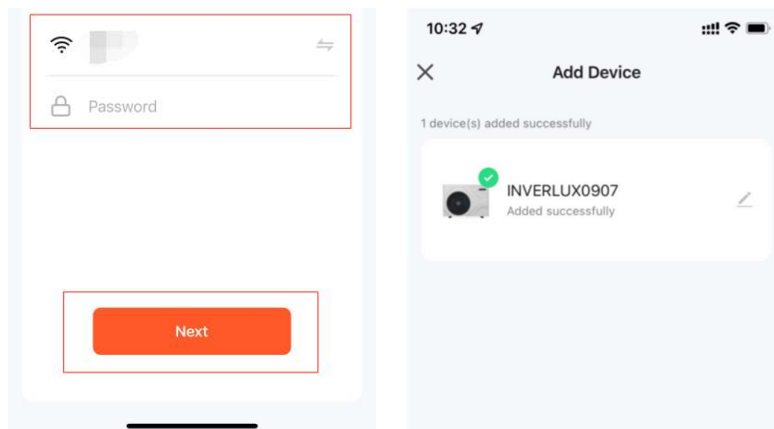

### 7.3 Connection share

Users who have successfully connected can freely share the link of the machine, so that other members can also control it through their mobile phone.

### 7.3.1 Use "Share Device" function and create a group to share the connection.

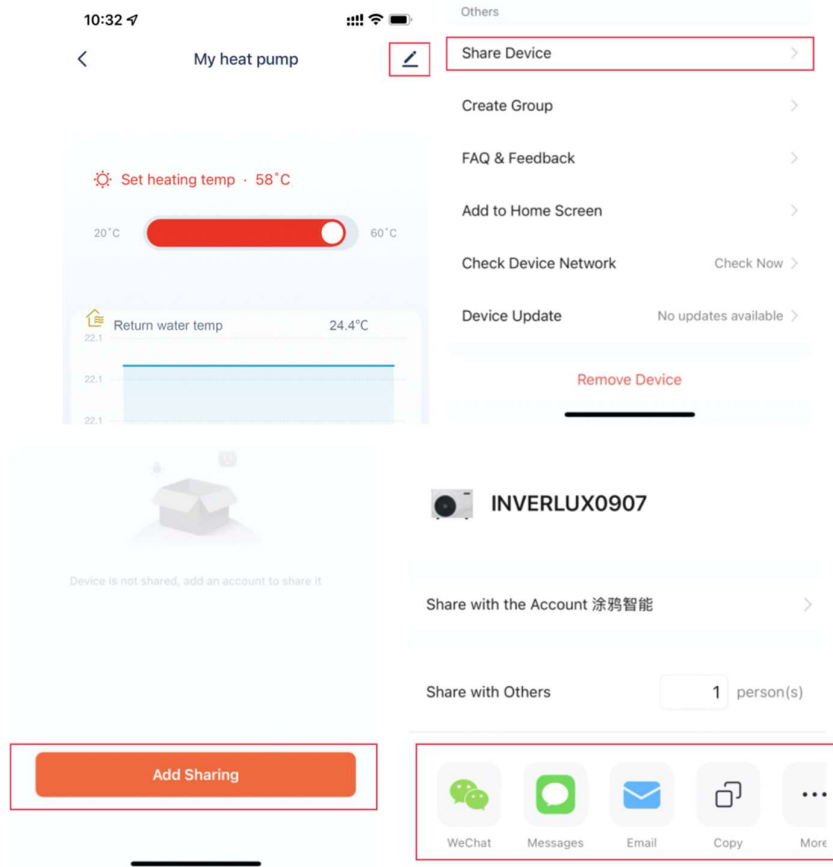

### 7.3.2 Operating mode, target temperature and work status control

- Turn on/off the heat pump by pressing "power".
- Adjust the target temperature by dragging the right end of the temperature bar around the temperature dial. Temperature regulation accuracy is  $\pm 0.1^{\circ}\text{C}$ .
- Changing work status by choosing "Heating" "Cooling".

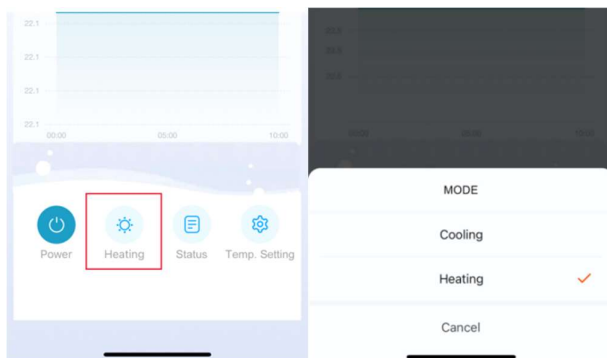

### 7.3.3 Status of the heat pump

The real-time status of heat pump can be queried through the "status" interface.



### 7.3.4 Setting of the heat pump

Press the "setting" button and enter the setting interface.

Only "Tank temperature" "Heating temperature" "Cooling temperature" can be adjusted.

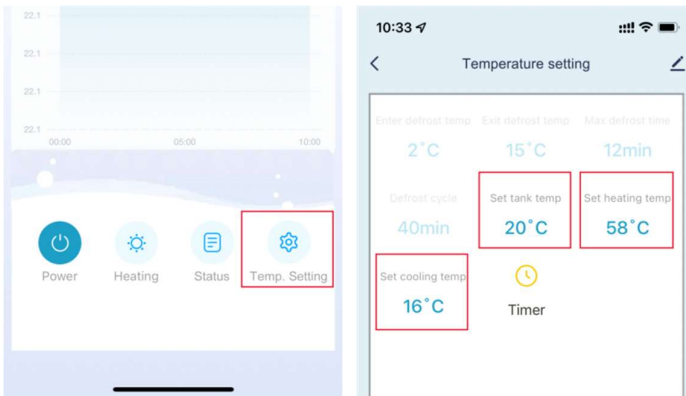

- Timer set up: press the "Timer".

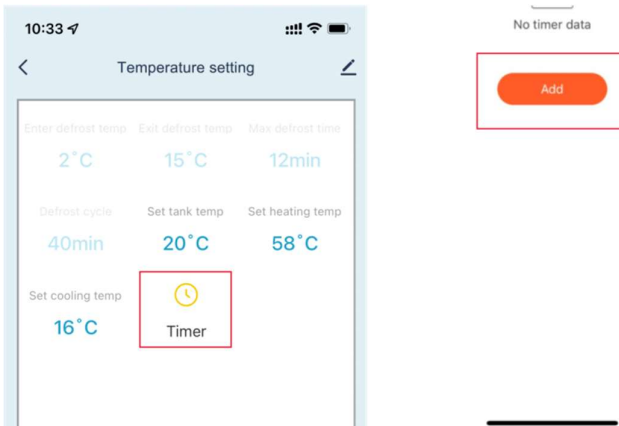



# 8 – ELECTRONIC PCB

Model: ALSAVO HEAT 07i/ALSAVO HEAT 10i

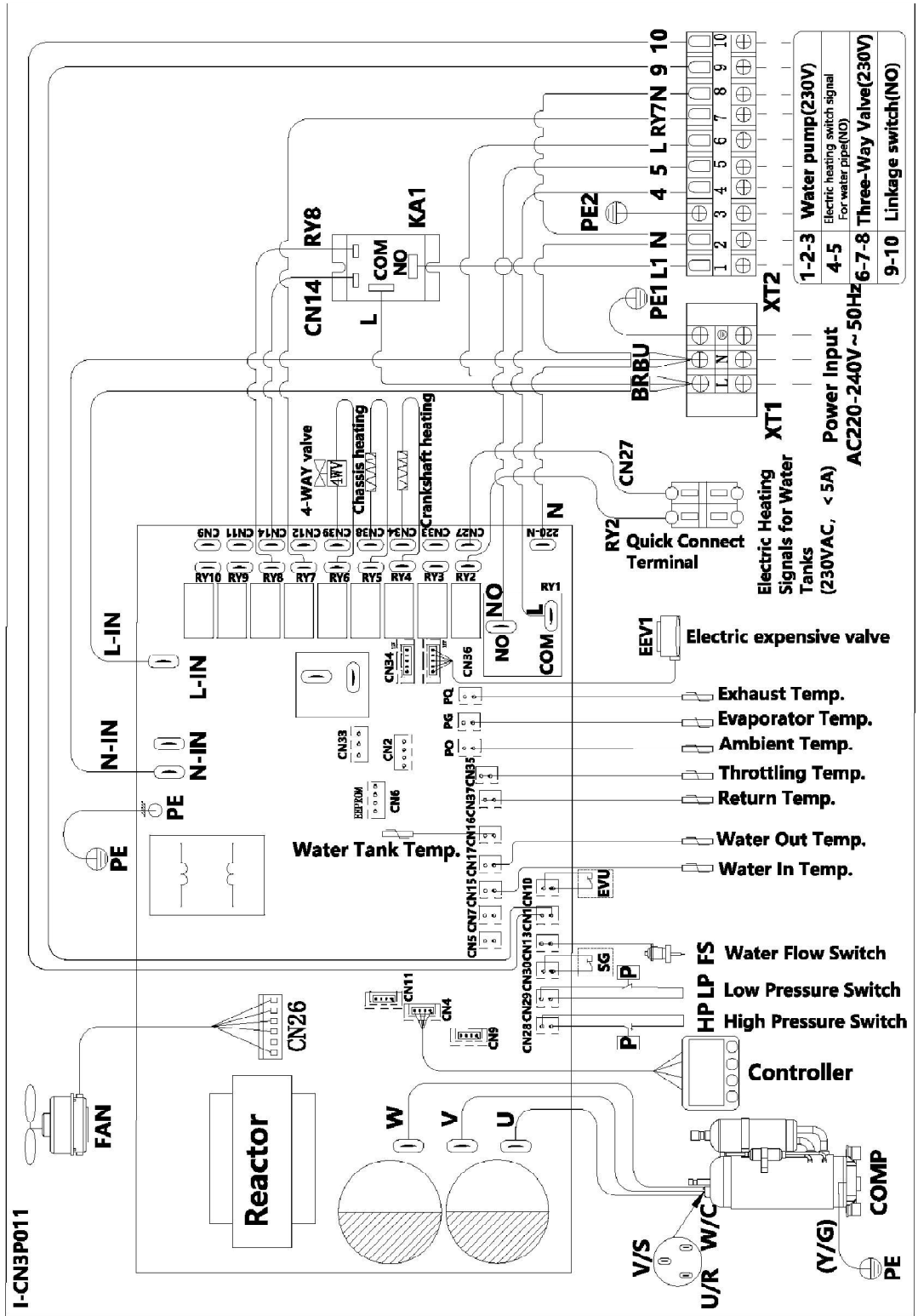

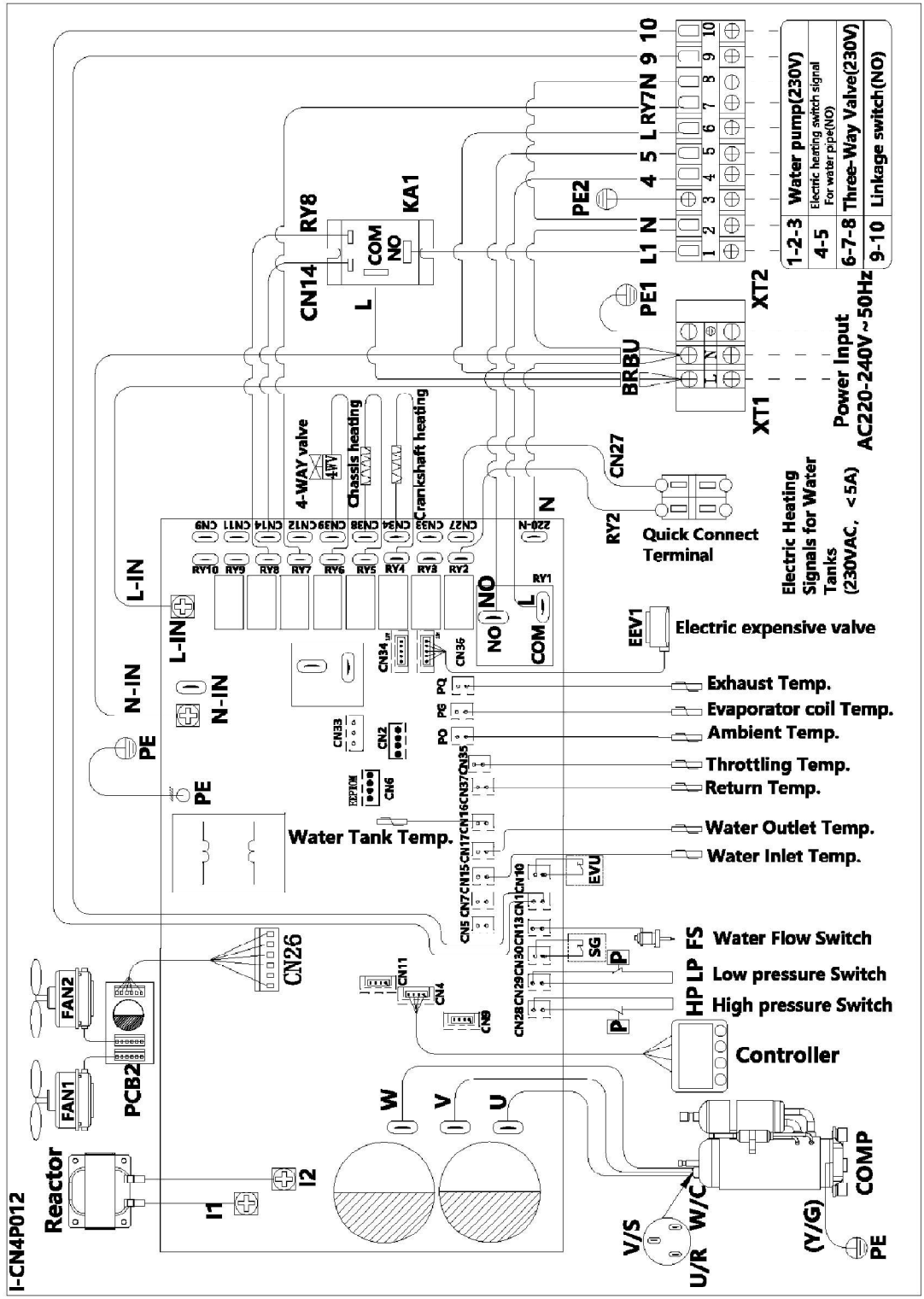

Model: ALSAVO HEAT 16i

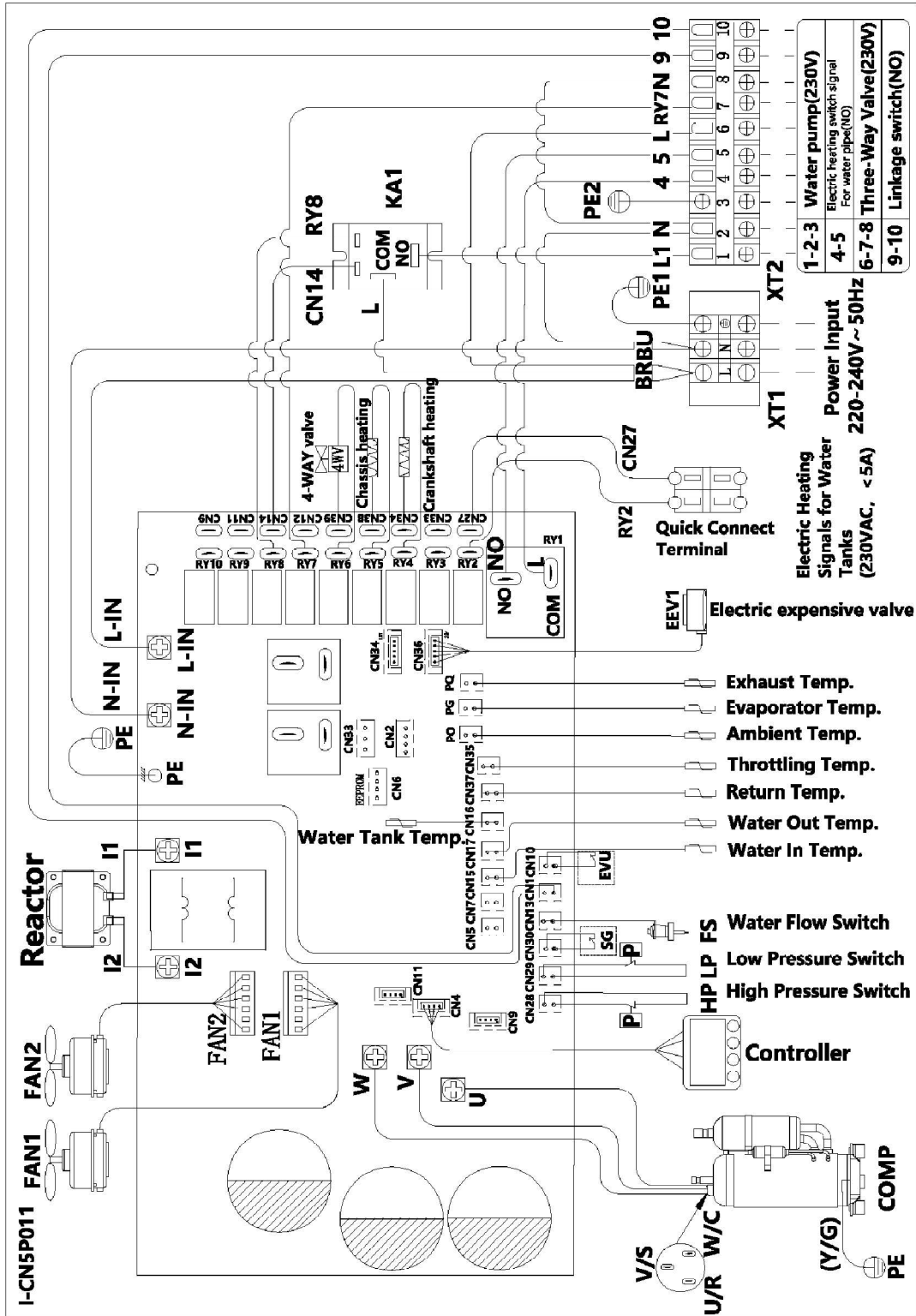

Model: ALSAVO HEAT 12iT/ALSAVO HEAT 16iT

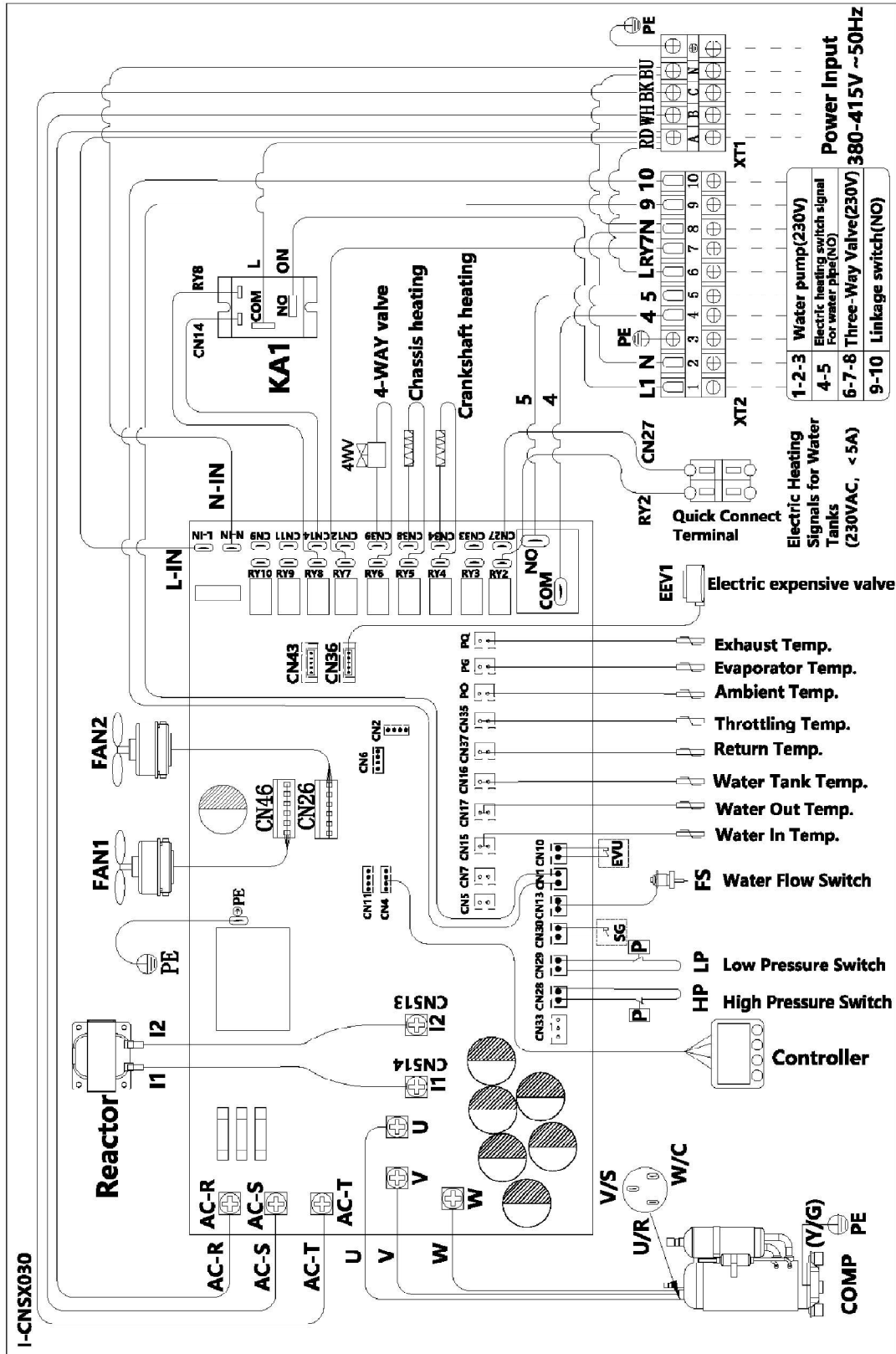

**Note:**



- 1) Must be hard wired, plug is not allowed. Must comply with 60245 IEC57.
- 2) The heat pump must be earthed well.
- 3) means for disconnection must be incorporated in the fixed wiring in accordance with the wiring.
- 4) The machine is connected to the fixed wiring by a set of power supply cords, which must be connected and installed with an all-pole disconnection device whose contact opening distance meets the condition of overvoltage class III.

References for protecting devices and cable specification

Model	Maximum current	Breaker Fuse	Power Cord	Recommended RCD
ALSAVO HEAT 07i	14A	25A	3 x 2.5mm <sup>2</sup>	30mA
ALSAVO HEAT 10i	16A	32A	3 x 4mm <sup>2</sup>	30mA
ALSAVO HEAT 12i	23A	32A	3 x 4mm <sup>2</sup>	30mA
ALSAVO HEAT 16i	26A	40A	3 x 6mm <sup>2</sup>	30mA
ALSAVO HEAT 12iT	12A	32A	5 x 2.5mm <sup>2</sup>	30mA
ALSAVO HEAT 16iT	14A	32A	5 x 2.5mm <sup>2</sup>	30mA

※ Above data is subject to modification without notice.

# 9 – EXPLODED VIEW

Schema: ALSAVO HEAT 07i

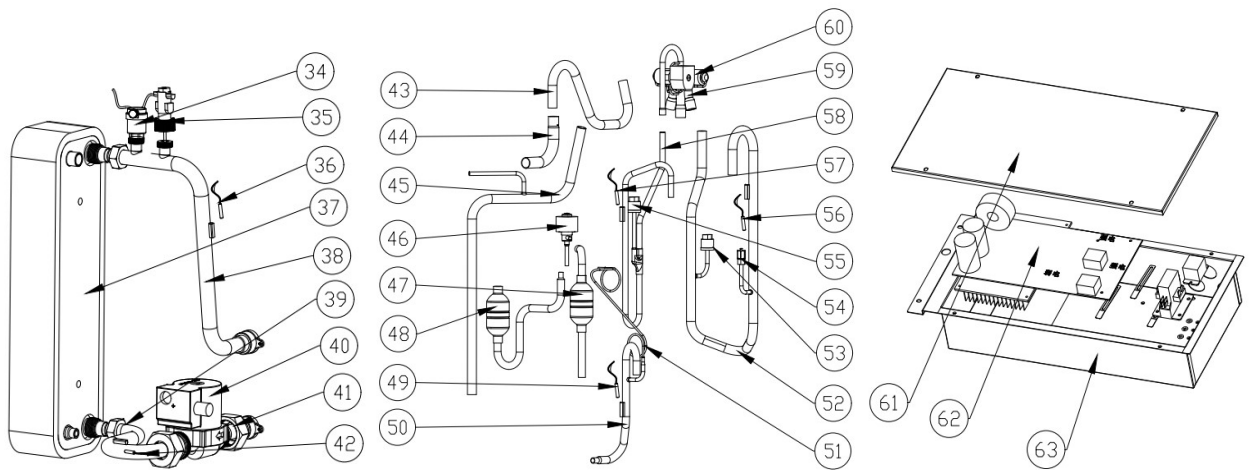
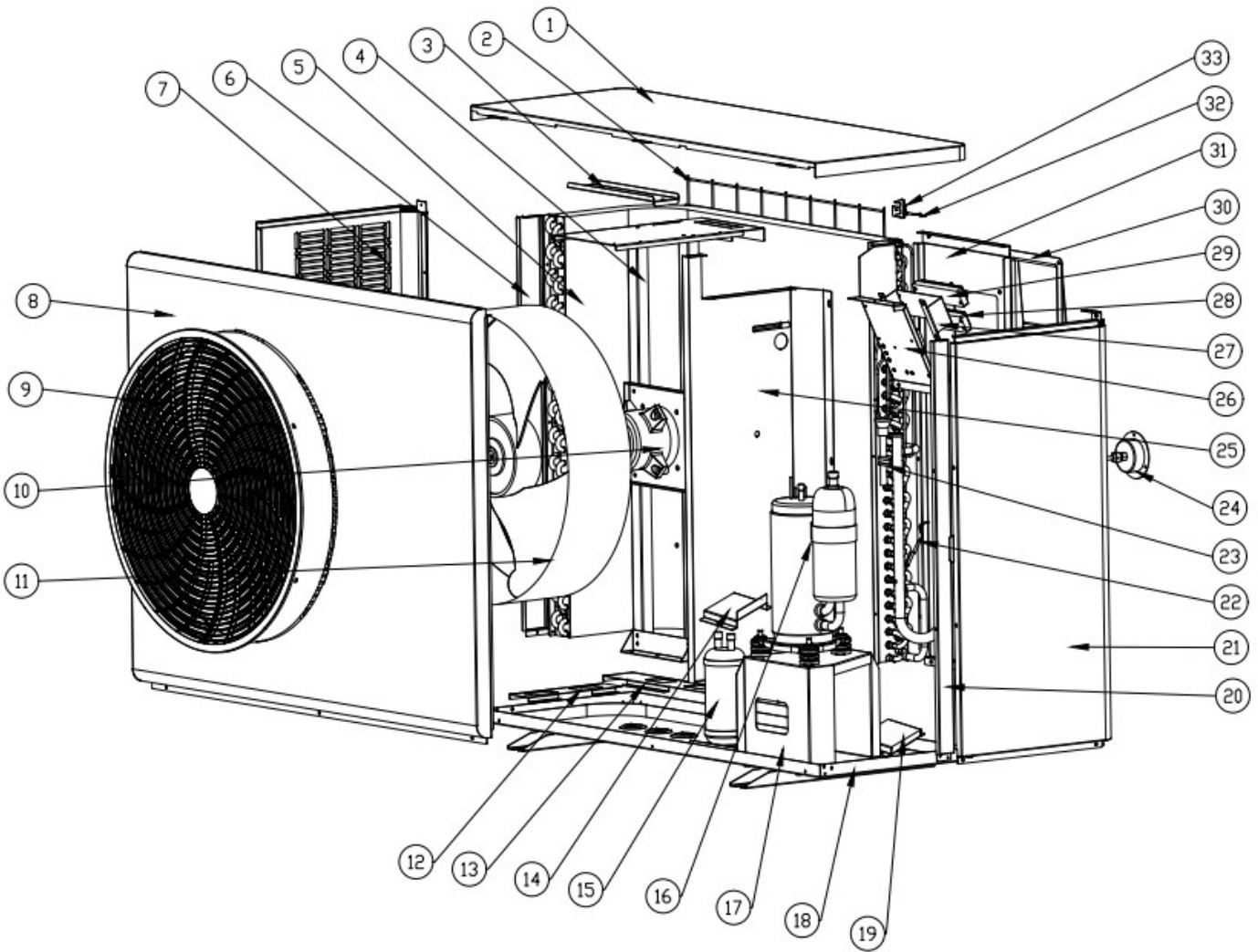

**Parts: ALSAVO HEAT 07i**

ALSAVO HEAT 07i					
NO.	ERP	Part Name	NO.	ERP	Part Name
1	108540174-1	Top cover	33	133020010	Ambient temp sensor clip
2	108540076	Back grille	34	120000126	Exhaust valve
3	108540125	Support plate	35	116000118	Water flow switch
4	108540136	Motor bracket	36	117110182	Water out temp sensor
5	103000423	Evaporator	37	102030014	Plate heat exchanger
6	108540141	Evaporator plate	38	113560026	Pipe
7	108540176-1	Left panel	39	113560010	Pipe
8	108540147-1	Front Panel	40	107000031	Water pump
9	133020079	Ventilation	41	113560011	Pipe
10	112000031	Fan motor	42	117110181	Water in temp sensor
11	132000023	Fan blade	43	113210011	Pipe
12	108540142	Evaporator support plate 1	44	113320017	Pipe
13	108540143	Evaporator support plate 2	45	113060238	Pipe
14	108540140	Plate exchanger support plate	46	119000056	EEV
15	105000004	Reservoir	47	113120088	Pipe
16	101000223	Compressor	48	113080170	Pipe
17	108540144	Compressor support plate	49	117110186	Throttling temp sensor
18	108540155	Base plate	50	113320025	Pipe
19	108540156	Water pump bracket	51	109000038	Capillary
20	108540139	Pillar	52	113020735	Gas return pipe
21	108540177-1	Right panel	53	116000122	Low pressure switch
22	117110181	Evaporator temp sensor	54	120000097	Gas valve
23	136020005	Rubber	55	116000120	High pressure switch
24	106000012	Pressure gauge	56	117110185	Return temp sensor
25	108540171	Isolation plate	57	117110184	Exhaust temp sensor
26	108470160	Terminal plate	58	113010488	Exhaust pipe
27	108470161	Terminal frame	59	121000024	Four-way valve
28	115000070	Terminal	60	121000037	Four-way valve coil
29	115000025	Terminal	61	108540138	Electric control box cover
30	133030022	Wiring cover	62	117100100	PCB
31	108540175-1	Back panel	63	108540137	Electric control box
32	117110183	Ambient temp sensor			

**Schema: ALSAVO HEAT 10i**

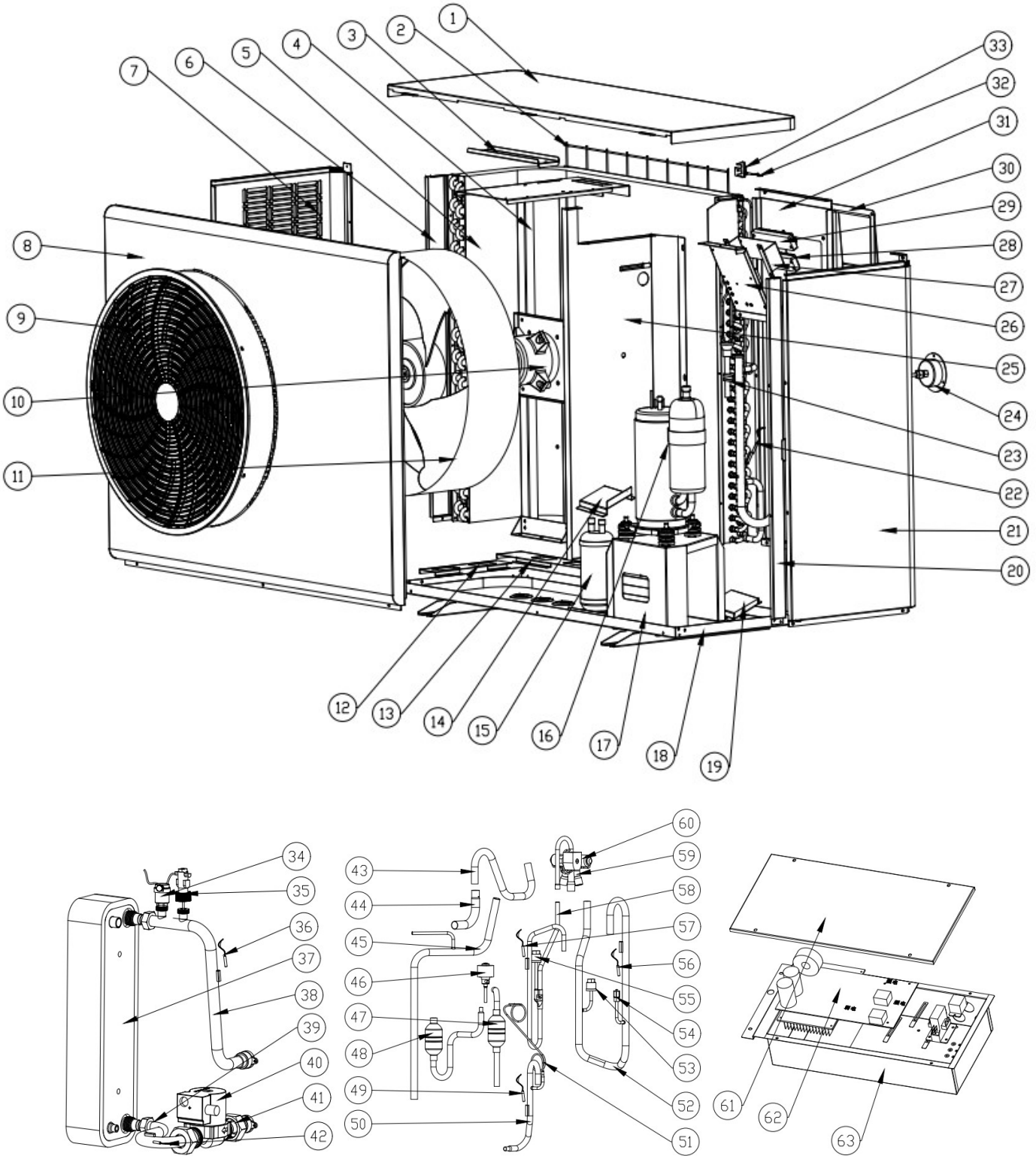

**Parts: ALSAVO HEAT 10i**

ALSAVO HEAT 10i					
NO.	ERP	Part Name	NO.	ERP	Part Name
1	108540174-1	Top cover	33	133020010	Ambient temp sensor clip
2	108540076	Back grille	34	120000126	Exhaust valve
3	108540125	Support plate	35	116000118	Water flow switch
4	108540136	Motor bracket	36	117110182	Water out temp sensor
5	103000423	Evaporator	37	102030014	Plate heat exchanger
6	108540141	Evaporator plate	38	113560026	Pipe
7	108540176-1	Left panel	39	113560010	Pipe
8	108540147-1	Front panel	40	107000031	Water pump
9	133020079	Ventilation	41	113560011	Pipe
10	112000031	Fan motor	42	117110181	Water in temp sensor
11	132000023	Fan blade	43	113210011	Pipe
12	108540142	Evaporator support plate 1	44	113320017	Pipe
13	108540143	Evaporator support plate 2	45	113060238	Pipe
14	108540140	Plate exchanger support plate	46	119000056	EEV
15	105000004	Reservoir	47	113120075	Pipe
16	101000267	Compressor	48	113080170	Pipe
17	108540144	Compressor support plate	49	117110186	Throttling temp sensor
18	108540155	Base plate	50	113320025	Pipe
19	108540156	Water pump bracket	51	109000038	Capillary
20	108540139	Pillar	52	113020735	Gas return pipe
21	108540177-1	Right panel	53	116000122	Low pressure switch
22	117110181	Evaporator temp sensor	54	120000097	Gas valve
23	136020005	Rubber	55	116000120	High pressure switch
24	106000012	Pressure gauge	56	117110185	Return temp sensor
25	108540171	Isolation plate	57	117110184	Exhaust temp sensor
26	108470160	Terminal plate	58	113010488	Exhaust pipe
27	108470161	Terminal frame	59	121000024	Four-way valve
28	115000070	Terminal	60	121000037	Four-way valve coil
29	115000025	Terminal	61	108540138	Electric control box cover
30	133030022	Wiring cover	62	117100100	PCB
31	108540175-1	Back panel	63	108540137	Electric control box
32	117110183	Ambient temp sensor			

**Schema: ALSAVO HEAT 12i**

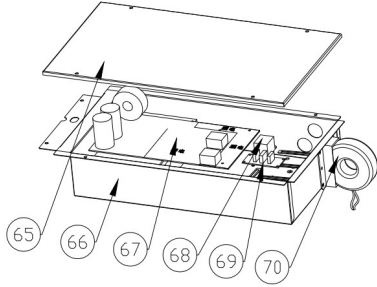
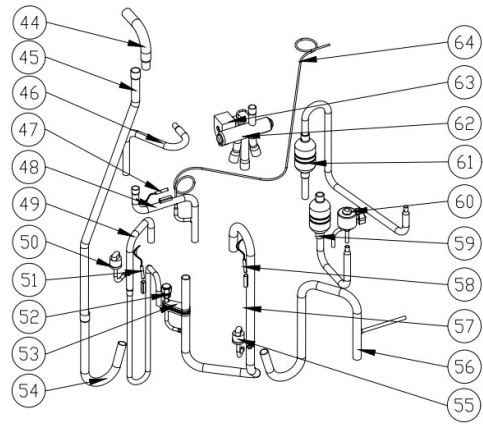
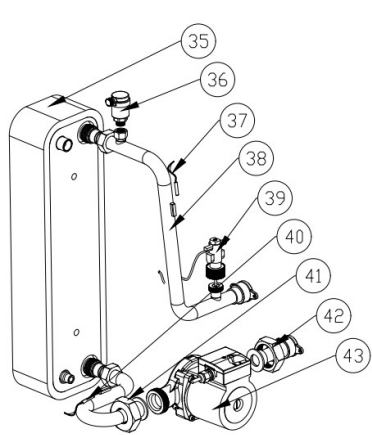
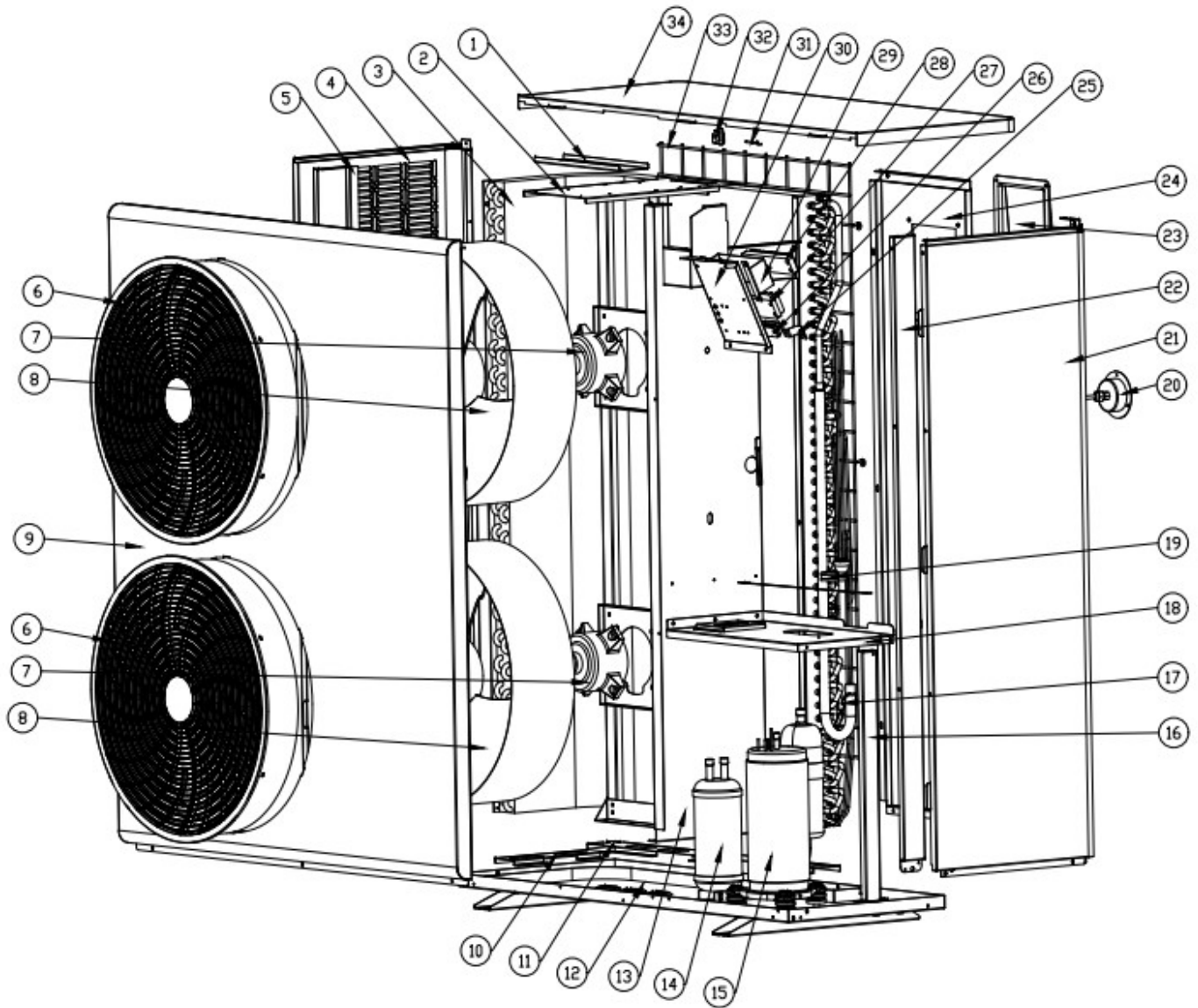

**Parts: ALSAVO HEAT 12i**

ALSAVO HEAT 12i					
NO.	ERP	Part Name	NO.	ERP	Part Name
1	108470197	Support plate	36	120000126	Exhaust valve
2	108470215	Motor bracket	37	117110192	Water out temp sensor
3	103000429	Evaporator	38	113560028	Pipe
4	108470206-1	Left panel	39	116000118	Water flow switch
5	108470162	Evaporator plate	40	117110191	Water in temp sensor
6	133020078	Ventilation	41	113560027	Pipe
7	112000031	Fan motor	42	113560011	Pipe
8	132000015	Fan blade	43	107000032	Water pump
9	108470207-1	Front panel	44	113320023	Pipe
10	108470164	Evaporator plate	45	113210015	Pipe
11	108540143	Evaporator support plate 2	46	113320043	Pipe
12	108470200	Base plate	47	117110195	Throttling temp sensor
13	108470194	Isolation plate	48	113220013	Pipe
14	105000015	Reservoir	49	113010509	Exhaust pipe
15	101000267	Compressor	50	116000121	High pressure switch
16	108470202	Right support plate	51	117110193	Exhaust temp sensor
17	117110191	Evaporator temp sensor	52	120000097	Gas valve
18	108470196	Plate exchanger support plate	53	136020154	Pipe fixing block
19	136020005	Rubber	54	113210014	Pipe
20	106000012	Pressure gauge	55	116000122	Low pressure switch
21	108470203-1	Right panel	56	113020741	Pipe
22	108470170	Pillar	57	113020771	Gas return pipe
23	133030022	Wiring cover	58	117110194	Return temp sensor
24	108470205-1	Back panel	59	113120093	Pipe
25	136010004	Crimping clip	60	119000079	EEV
26	108010086	Crimping clip	61	113080169	Pipe
27	115000025	Terminal	62	121000028	Four-way valve
28	115000070	Terminal	63	121000038	Four-way valve coil
29	108470160	Terminal plate	64	109000116	Capillary
30	108470161	Terminal frame	65	108470176	Electric control box cover
31	117110183	Ambient temp sensor	66	108470193	Electronic control box
32	133020010	Ambient temp sensor clip	67	117100098	PCB
33	108470014	Back grille	68	142000038	30A air conditioning relay
34	108470204-1	Top cover	69	117010081	Distribution boards 1-2
35	102030016	Plate heat exchanger	70	117220006	PFC inductor

**Schema: ALSAVO HEAT 12iT**

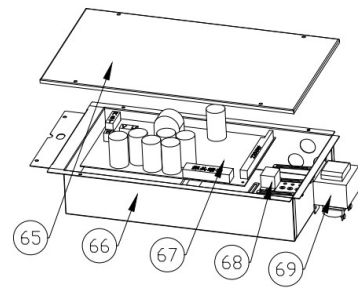
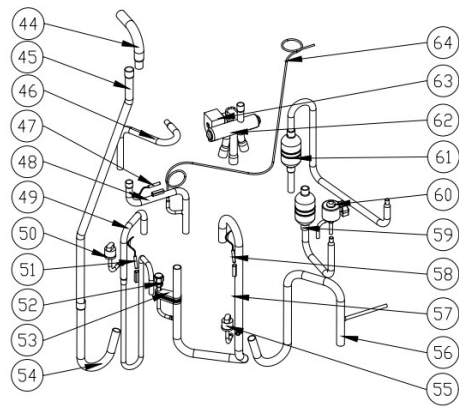
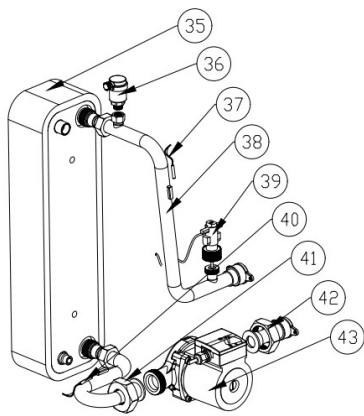
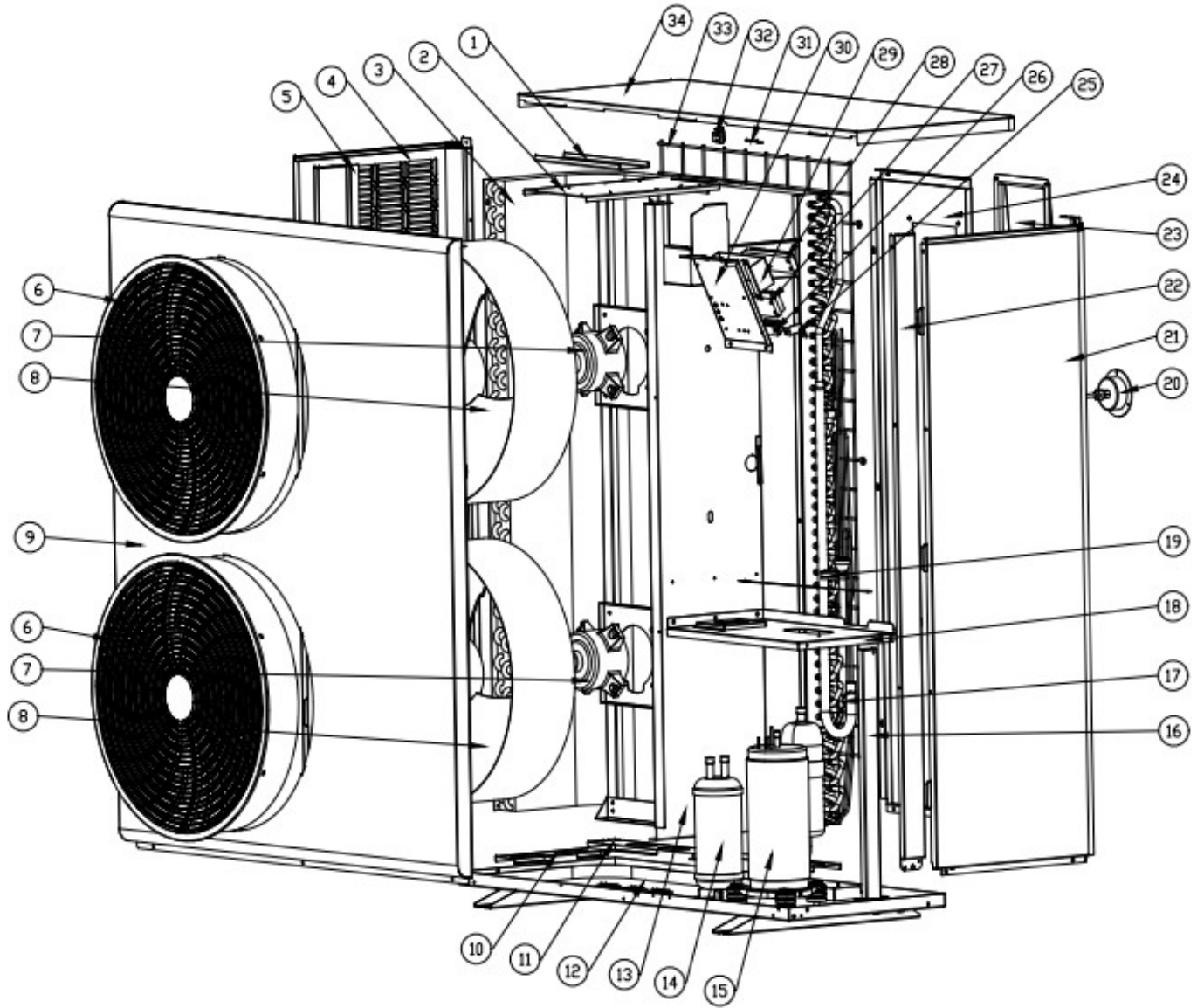

**Parts: ALSAVO HEAT 12iT**

ALSAVO HEAT 12iT					
NO.	ERP	Part Name	NO.	ERP	Part Name
1	108470197	Support plate	36	120000126	Exhaust valve
2	108470215	Motor bracket	37	117110192	Water out temp sensor
3	103000429	Evaporator	38	113560024	Pipe
4	108470206-1	Left panel	39	116000118	Water flow switch
5	108470162	Evaporator plate	40	117110191	Water in temp sensor
6	133020078	Ventilation	41	113560024	Pipe
7	112000031	Fan motor	42	113560035	Pipe
8	132000015	Fan blade	43	107000032	Water pump
9	108470207-1	Front panel	44	113320023	Pipe
10	108470164	Evaporator plate	45	113210020	Pipe
11	108540143	Evaporator support plate 2	46	113320026	Pipe
12	108470200	Base plate	47	117110195	Throttling temp sensor
13	108470194	Isolation plate	48	113220013	Pipe
14	105000015	Reservoir	49	113010509	Exhaust pipe
15	101000267	Compressor	50	116000121	High pressure switch
16	108470202	Right support plate	51	117110193	Exhaust temp sensor
17	117110191	Evaporator temp sensor	52	120000097	Gas valve
18	108470196	Plate exchanger support plate	53	136020154	Pipe fixing block
19	136020005	Rubber	54	113210014	Pipe
20	106000012	Pressure gauge	55	116000122	Low pressure switch
21	108470203-1	Right panel	56	113020741	Pipe
22	108470170	Pillar	57	113020771	Gas return pipe
23	133030022	Wiring cover	58	117110194	Return temp sensor
24	108470205-1	Back panel	59	113120093	Pipe
25	136010004	Crimping clip	60	119000079	EEV
26	108010086	Crimping clip	61	113080169	Pipe
27	115000006	Terminal	62	121000028	Four-way valve
28	115000070	Terminal	63	121000038	Four-way valve coil
29	108470160	Terminal plate	64	109000116	Capillary
30	108470161	Terminal frame	65	108470176	Electric control box cover
31	117110183	Ambient temp sensor	66	108470192	Electronic control box
32	133020010	Ambient temp sensor clip	67	117100107	PCB
33	108470014	Back grille	68	142000038	30A air conditioning relay
34	108470204-1	Top cover	69	117230015	Reactor
35	102030023	Plate heat exchanger			

**Schema: ALSAVO HEAT 16i**

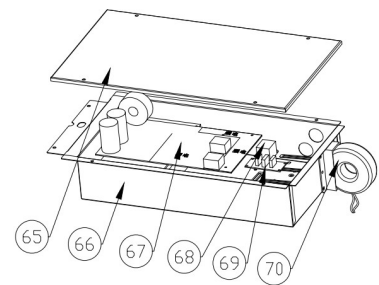
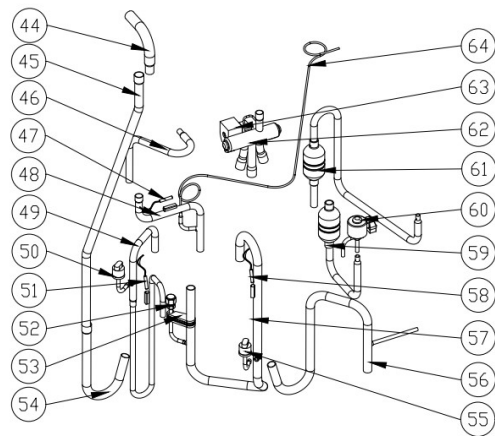
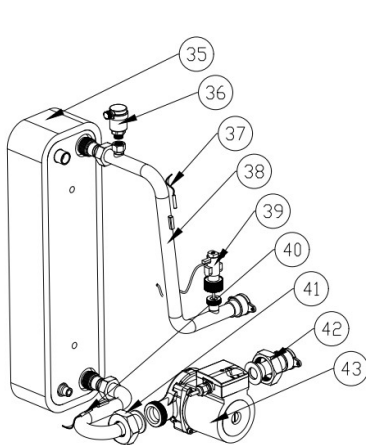
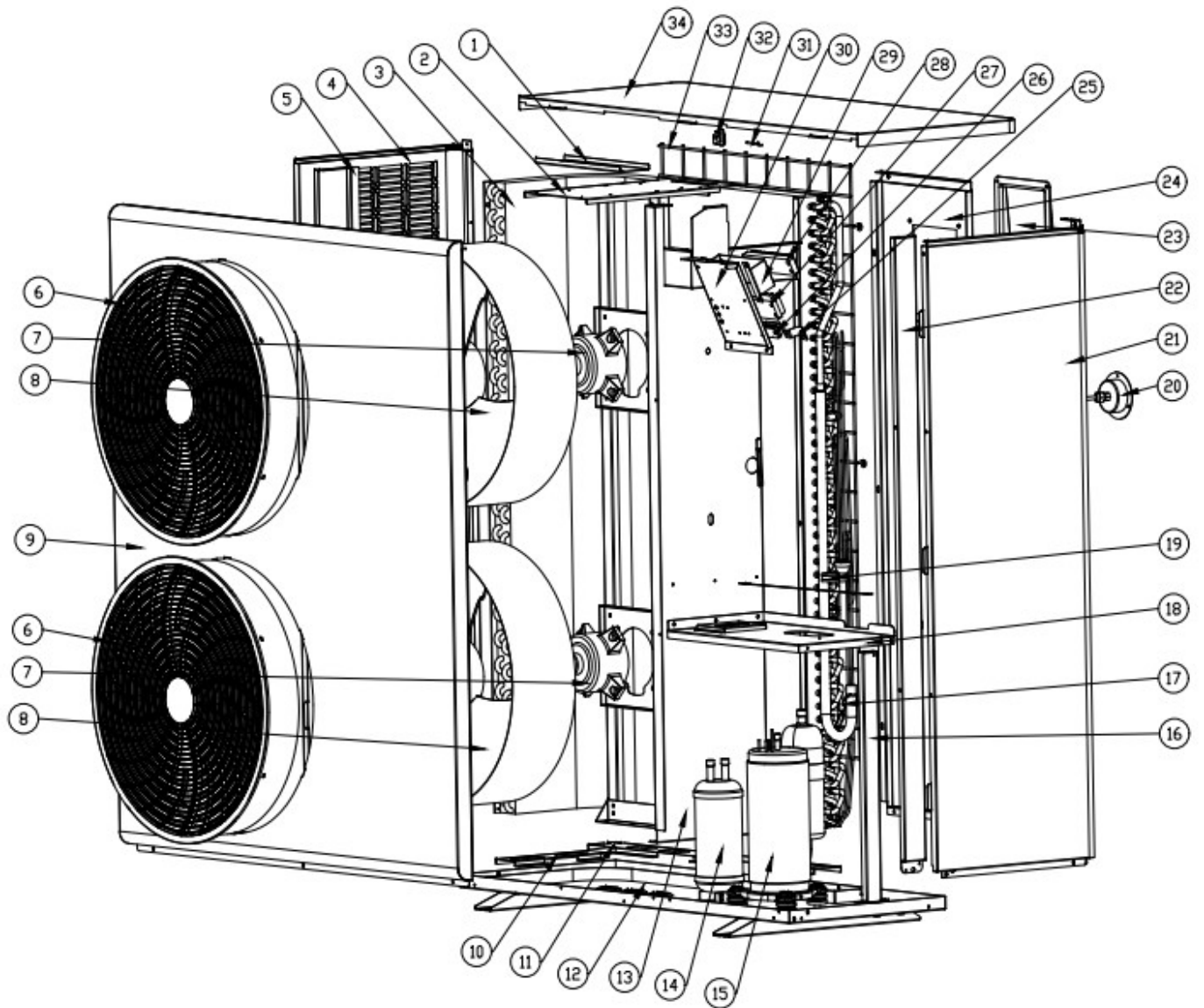

**Parts: ALSAVO HEAT 16i**

ALSAVO HEAT 16i					
NO.	ERP	Part Name	NO.	ERP	Part Name
1	108470197	Support plate	36	120000126	Exhaust valve
2	108470215	Motor bracket	37	117110192	Water out temp sensor
3	103000448	Evaporator	38	113560032	Pipe
4	108470206-1	Left panel	39	116000118	Water flow switch
5	108470162	Evaporator plate	40	117110191	Water in temp sensor
6	133020078	Ventilation	41	113560031	Pipe
7	112000031	Fan motor	42	113560011	Pipe
8	132000015	Fan blade	43	107000032	Water pump
9	108470207-1	Front panel	44	113320023	Pipe
10	108470164	Evaporator plate	45	113210020	Pipe
11	108540143	Evaporator support plate 2	46	113320031	Pipe
12	108470200	Base plate	47	117110195	Throttling temp sensor
13	108470194	Isolation plate	48	113220013	Pipe
14	105000015	Reservoir	49	113010493	Exhaust pipe
15	101000239	Compressor	50	116000121	High pressure switch
16	108470202	Right support plate	51	117110193	Exhaust temp sensor
17	117110191	Evaporator temp sensor	52	120000097	Gas valve
18	108470196	Plate exchanger support plate	53	136020154	Pipe fixing block
19	136020005	Rubber	54	113210014	Pipe
20	106000012	Pressure gauge	55	116000122	Low pressure switch
21	108470203-1	Right panel	56	113020741	Pipe
22	108470170	Pillar	57	113020740	Gas return pipe
23	133030022	Wiring cover	58	117110194	Return temp sensor
24	108470205-1	Back panel	59	113120093	Pipe
25	136010004	Crimping clip	60	119000079	EEV
26	108010086	Crimping clip	61	113080164	Pipe
27	115000025	Terminal	62	121000028	Four-way valve
28	115000070	Terminal	63	121000038	Four-way valve coil
29	108470160	Terminal plate	64	109000116	Capillary
30	108470161	Terminal frame	65	108470176	Electric control box cover
31	117110183	Ambient temp sensor	66	108470193	Electronic control box
32	133020010	Ambient temp sensor clip	67	117100094	PCB
33	108470014	Back grille	68	142000038	30A air conditioning relay
34	108470204-1	Top cover	69	117010081	Distribution boards 1-2
35	102030031	Plate heat exchanger	70	117220006	PFC inductor

**Schema: ALSAVO HEAT 16iT**

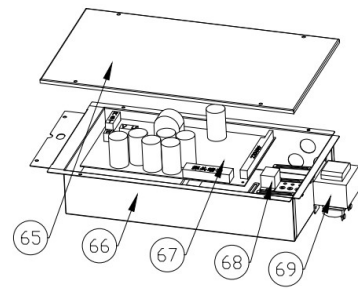
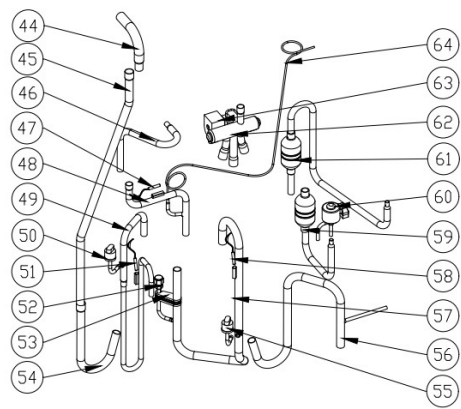
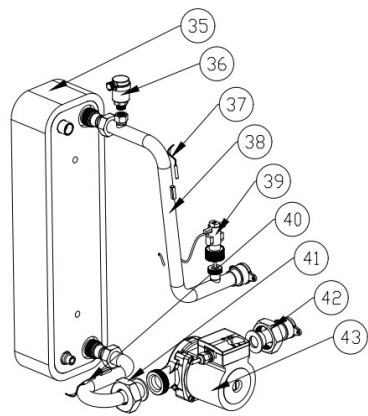
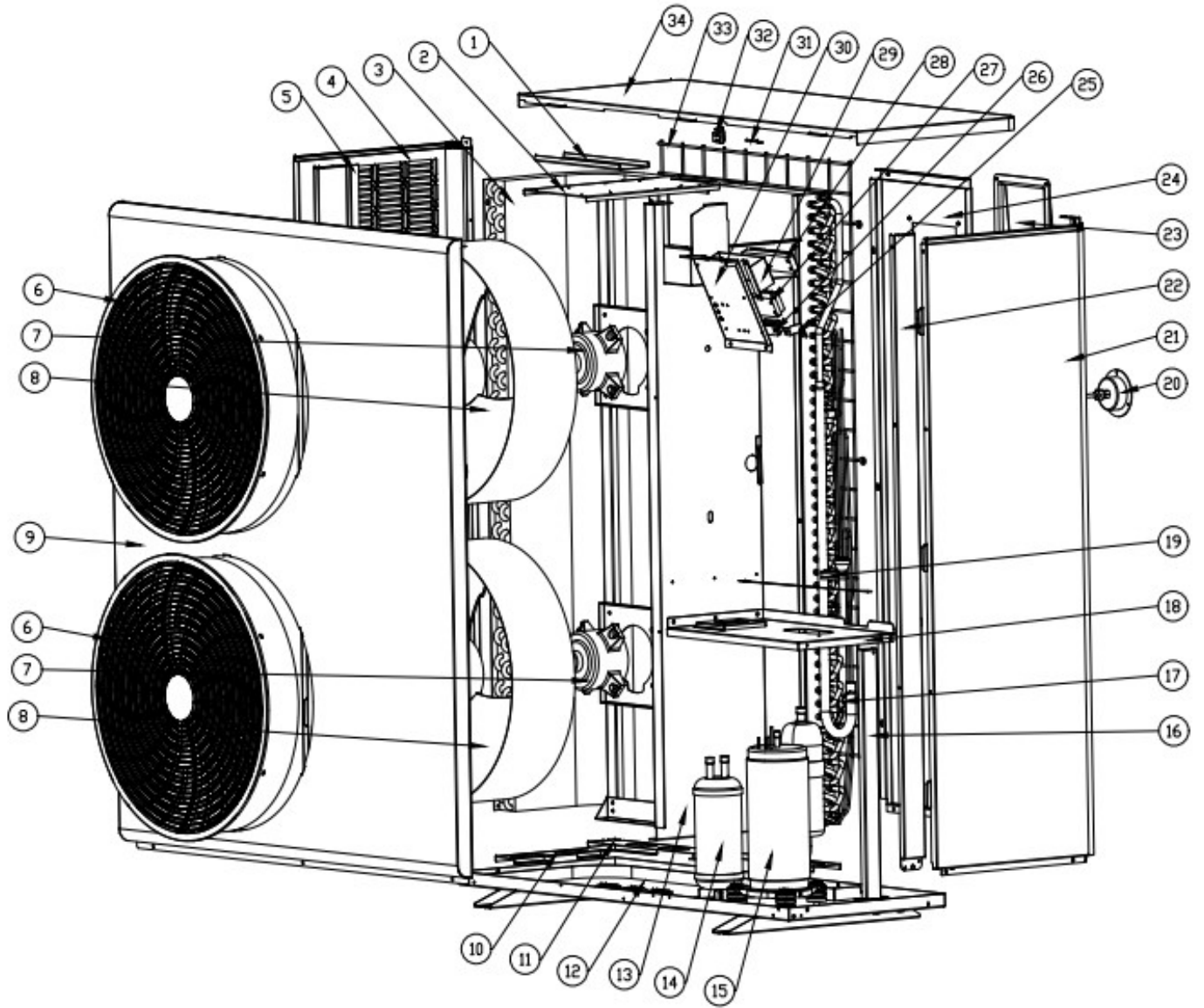

**Parts: ALSAVO HEAT 16iT**

ALSAVO HEAT 16iT					
NO.	ERP	Part Name	NO.	ERP	Part Name
1	108470197	Support plate	36	120000126	Exhaust valve
2	108470215	Motor bracket	37	117110192	Water out temp sensor
3	103000448	Evaporator	38	113560024	Pipe
4	108470206-1	Left panel	39	116000118	Water flow switch
5	108470162	Evaporator plate	40	117110191	Water in temp sensor
6	133020078	Ventilation	41	113560025	Pipe
7	112000031	Fan motor	42	113560011	Pipe
8	132000015	Fan blade	43	107000032	Water pump
9	108470207-1	Front panel	44	113320023	Pipe
10	108470164	Evaporator plate	45	113210020	Pipe
11	108540143	Evaporator support plate 2	46	113320031	Pipe
12	108470200	Base plate	47	117110195	Throttling temp sensor
13	108470194	Isolation plate	48	113220013	Pipe
14	105000015	Reservoir	49	113010493	Exhaust pipe
15	101000239	Compressor	50	116000121	High pressure switch
16	108470202	Right support plate	51	117110193	Exhaust temp sensor
17	117110191	Evaporator temp sensor	52	120000097	Gas valve
18	108470196	Plate exchanger support plate	53	136020154	Pipe fixing block
19	136020005	Rubber	54	113210014	Pipe
20	106000012	Pressure gauge	55	116000122	Low pressure switch
21	108470203-1	Right panel	56	113020741	Pipe
22	108470170	Pillar	57	113020740	Gas return pipe
23	133030022	Wiring cover	58	117110194	Return temp sensor
24	108470205-1	Back panel	59	113120093	Pipe
25	136010004	Crimping clip	60	119000079	EEV
26	108010086	Crimping clip	61	113080164	Pipe
27	115000025	Terminal	62	121000028	Four-way valve
28	115000070	Terminal	63	121000038	Four-way valve coil
29	108470160	Terminal plate	64	109000116	Capillary
30	108470161	Terminal frame	65	108470176	Electric control box cover
31	117110183	Ambient temp sensor	66	108470192	Electronic control box
32	133020010	Ambient temp sensor clip	67	117100108	PCB
33	108470014	Back grille	68	142000038	30A air conditioning relay
34	108470204-1	Top cover	69	117230015	Reactor
35	102030023	Plate heat exchanger			

## 10 – MAINTENANCE

The following points must be checked, measured, and controlled:

### **Heat pump unit**

- Electrical protections and connections, power supply voltage and current
- Air exchanger cleaning
- Condensate evacuation
- Fan operation
- Operating temperatures on air and water
- Apparent tightness of the refrigeration circuit

### **Whole installation**

- Filter cleaning
- Expansion vessel
- Operation of the circulator
- Heat water transfer fluid and antifreeze protection level
- Safety valve sealing and hydraulic components.
- Storage balloon protection
- Visual and auditory state of the whole installation, leakage, isolation...

### **Protection**

The heat pump as a protection anti-freezing function in running, but it was preconized to added glycol on the water circuit. This why is mandatory to disconnect electricity and shut down the heat pump during the winter season other way the function do not apply.

Or drain the water circuit to avoid any risk of freezing when the heat pump is OFF.

Post-intervention functional test

Explanations to the user and advice on how the system works.



This marking indicates that this product should not be disposed with other household wastes throughout the EU. To prevent possible harm to the environment or human health from uncontrolled waste disposal, recycle it responsibly to promote the sustainable reuse of material resources. To return your used device, please use the return and collection systems or contact the retailer where the product was purchased. They can take this product for environmental safe recycling.



ZEALUX France

8 Allée du Piot  
30660 GALLARGUES LE MONTUEUX  
France

**AAHP09**